

cdmaOne Measurement Guide

Agilent Technologies E4406A VSA Series Transmitter Tester



Agilent Technologies

Manufacturing Part Number: E4406-90147

Printed in USA

July 2000

© Copyright 1999 - 2000 Agilent Technologies, Inc.

The information contained in this document is subject to change without notice.

Agilent Technologies makes no warranty of any kind with regard to this material, including but not limited to, the implied warranties of merchantability and fitness for a particular purpose. Agilent Technologies shall not be liable for errors contained herein or for incidental or consequential damages in connection with the furnishing, performance, or use of this material.

Contents

1. Understanding cdmaOne	
What Is the cdmaOne (IS-95) Communication System?	6
What Does the Agilent E4406A VSA Series Transmitter Tester Do?	8
Other Sources of Measurement Information	9
Instrument Updates at www.agilent.com/find/vsa	9
2. Setting Up the cdmaOne Mode	
Accessing the Mode	12
How to Make a Measurement	13
Changing the Mode Setup	14
Radio	14
Input	14
Trigger	16
Demod	17
Changing the Frequency Channel	19
cdmaOne Measurement Key Flow	20
Installing Optional	
Measurement Personalities	33
Available Personality Options	34
License Key Numbers	35
Installing a License Key Number	36
Using the Uninstall Key	37
3. Making cdmaOne Measurements	
cdmaOne Measurements	40
Preparing for Measurements	41
Initial Setup	41
Measure Control	42
Measurement Setup	42
Making the Channel Power Measurement	45
Purpose	45
Measurement Method	45
Making the Measurement	45
Results	46
Changing the Measurement Setup	47
Changing the Display	48
Troubleshooting Hints	49
Making the Modulation Accuracy (Rho) Measurement	50
Purpose	50
Measurement Method	50
Making the Measurement	51
Results	52
Changing the Measurement Setup	54
Changing the View	55
Changing the Display	55
Making the Code Domain Measurement	
(Base Station Only)	56
Purpose	56

Contents

Measurement Method	56
Making the Measurement	57
Results	58
Changing the Measurement Setup	59
Changing the View	60
Changing the Display	60
Making the Spur Close Measurement	61
Purpose	61
Measurement Method	61
Making the Measurement	63
Results	64
Changing the Measurement Setup	66
Changing the View	66
Making the Spectrum (Frequency Domain) Measurement	67
Purpose	67
Measurement Method	67
Making the Measurement	67
Results	67
Changing the Measurement Setup	69
Changing the View	73
Using the Markers	73
Troubleshooting Hints	74
Making the Waveform (Time Domain) Measurement	75
Purpose	75
Measurement Method	75
Making the Measurement	75
Results	76
Changing the Measurement Setup	77
Changing the View	80
Using the Markers	80
Troubleshooting Hints	81
Making the Adjacent Channel Power Ratio (ACPR) Measurement	82
Purpose	82
Measurement Method	82
Making the Measurement	84
Results	84
Changing the Measurement Setup	86
Changing the View	92
Troubleshooting Hints	93

1 Understanding cdmaOne

What Is the cdmaOne (IS-95) Communication System?

Code Division Multiple Access (CDMA) is a direct sequence spread-spectrum digital communications technique that was originally designed for military applications. The main advantages of CDMA over other types of communications schemes are:

- greater capacity than with other techniques
- immunity to signal loss and degradation in the presence of high broadband interference
- immunity to signal loss and degradation due to multipath, scatter, and fading
- power consumption of mobile stations is strictly minimized (by base station control)
- supports full 9600 baud capability for voice and data communications
- provides increased security

CDMA uses correlative codes to distinguish one user from another. Frequency division is still used, as is done with Frequency Division Multiple Access (FDMA) and Time Division Multiple Access (TDMA), but in a much larger bandwidth (1.25 MHz). CDMA uses a direct sequence spread spectrum technique that realizes increased capacity from 1:1 frequency reuse and sectored cells. The capacity limit is soft. That is, capacity can be increased with some degradation of the error rate or voice quality.

In cdmaOne, a single user's channel consists of a specific frequency combined with a unique code. Correlative codes allow each user to operate in the presence of substantial interference. The interference is the sum of all other users on the same cdmaOne frequency, both from within and without the home cell, and from delayed versions of these signals. It also includes the usual thermal noise and atmospheric disturbances. Delayed signals caused by multipath are separately received and combined in cdmaOne. One of the major differences in access is that any cdmaOne frequency can be used in all sectors of all cells. This is possible because cdmaOne is designed to decode the proper signal in the presence of high interference.

The cdmaOne communication system is defined in the following Electronics Industry Association (EIA) and Telecommunications Industry Association (TIA) documents:

- TIA/EIA/
IS-95-A Mobile Station - Base Station Compatibility Standard for Dual-Mode Wideband Spread Spectrum Cellular System
- TIA/EIA-97-B Recommended Minimum Performance Standards for Base Stations Supporting Dual-Mode Wideband Spread Spectrum Cellular Mobile Stations
- TIA/EIA-98-B Recommended Minimum Performance Standards for dual-Mode Wideband Spread Spectrum Cellular Mobile Stations

And the following American National Standards Institute (ANSI) documents:

- J-STD-008 Personal Station-Base Station Compatibility Requirements for 1.8 to 2.0 GHz Code Division Multiple Access (CDMA) Personal Communications Systems
- J-STD-018 Recommended Minimum Performance Requirements for 1.8 to 2.0 GHz Code Division Multiple Access (CDMA) Personal Stations
- J-STD-019 Recommended Minimum Performance Requirements for Base Stations Supporting 1.8 to 2.0 GHz Code Division Multiple Access (CDMA) Personal Stations

What Does the Agilent E4406A VSA Series Transmitter Tester Do?

This instrument can help determine if a cdmaOne transmitter is working correctly. When configured for cdmaOne, the instrument can be used for the testing of a cdmaOne transmitter, according to the Electronics Industry Association and Telecommunications Industry Association TIA/EIA/IS-95A, TIA/EIA-97B, and TIA/EIA-98B documents and American National Standards Institute (ANSI) documents: J-STD-008, J-STD-018 and J-STD-019. These documents define complex, multi-part measurements used to maintain an interference-free environment. For example, the documents include measuring the power of a carrier. The Agilent E4406A automatically makes these measurements using the measurement methods and limits defined in the standards. The detailed results displayed by the measurements allow you to analyze cdmaOne system performance. You may alter the measurement parameters for specialized analysis.

For infrastructure test, the instrument will test base station transmitters in a non-interfering manner by means of a coupler or power splitter.

This instrument makes the following measurements:

- Channel Power
- Modulation Accuracy (Rho)
- Spurious Close
- ACPR (Adjacent Channel Power Ratio)
- Code Domain - power, timing, and phase
- Spectrum (Frequency Domain)
- Waveform (Time Domain)

Other Sources of Measurement Information

Additional measurement application information is available through your local Agilent sales and service office. The following application notes treat digital communications measurements in much greater detail than discussed in this measurement guide.

- Digital Modulation in Communications Systems - An Introduction
Application Note 1298
Part number 5965-7160E
- Understanding CDMA Measurements for Base Stations and Their Components
Application Note 1311
Part number 5968-0953E
- HPSK Spreading for 3GPP
Application Note 1335
Part number 5968-8438E
- E4406A Self-Guided Demo
Product Note
Part number 5968-7617E

Instrument Updates at www.agilent.com/find/vsa

This web location can be used to access the latest information about the transmitter tester.

2 **Setting Up the cdmaOne Mode**

Accessing the Mode

At initial power up, the transmitter tester will come up in the Basic mode, with the Spectrum (Frequency Domain) measurement selected and the Measure menu displayed.

To access the cdmaOne measurement personality, press the **Mode** key and select the **cdmaOne** key.

If you want to set the mode to a known factory default state, press **Preset**. This will preset the mode setup and all of the measurements to the factory default parameters.

NOTE

Note that pressing the **Preset** key does not switch instrument modes.

You may want to install a new personality, reinstall a personality that you have previously uninstalled, or uninstall a personality option. Instructions can be found in “Installing Optional Measurement Personalities” at the end of this section.

How to Make a Measurement

Follow the three-step process shown in the table below:

Step	Primary Key	Setup Keys	Related Keys
1. Select & setup a mode	Mode	Mode Setup, Input, Frequency Channel	System
2. Select & setup a measurement	Measure	Meas Setup	Meas Control, Restart
3. Select & setup view	View/Trace	Span X Scale, Amplitude Y Scale, Display, Next Window, Zoom	File, Save, Print, Print Setup, Marker, Search

Changing the Mode Setup

Numerous settings can be changed at the mode level by pressing the **Mode Setup** key. This will access a menu with the selections listed below. These settings affect all the measurements in the cdmaOne mode.

Radio

The **Radio** key accesses a menu to select:

- **Band** - Select IS-95A or J-STD-008.
- **Device** - Select the device to test (base station or mobile station).

Radio Default Settings	
Band	IS-95A
Device	Base

Input

The **Input** key accesses a menu to select the following. (You can also access this menu from the front-panel key **Input**.)

- **Input Port** - Choose between RF, I/Q, I Only, 50 MHz Ref, and IF Align.
- **RF Input Range** - To set the RF input range, choose **Auto** or **Manual**. If **Auto** is chosen, the instrument automatically sets the attenuator based on the power level of the carrier (where it is tuned). If there are multiple carriers present, the total power might overdrive the front end. In this case you need to set the **RF Input Range** to **Manual** and enter the expected **Max Total Pwr**. **Manual** is also used if you want to hold the input attenuation constant (for the best relative power accuracy). For single carriers it is generally recommended to set the **RF Input Range** to **Auto**.
- **Max Total Pwr** - To set the maximum total power at the UUT (Unit Under Test). This is the maximum expected value of the mean carrier power referenced to the output of the UUT (may include multiple carriers). The **Max Total Pwr** setting is coupled to the **Input Atten** setting. If **RF Input Range** is set to **Auto**, and **Max Total Pwr** is changed, **RF Input Range** is switched to **Manual**.
- **Input Atten** - To set the input attenuator setting. The **Input Atten** setting is coupled to the **Max Total Pwr** setting. The **Input Atten** key reads out the actual hardware value that will be used for the current measurement. If more than one input attenuator value is used in a single measurement, the value used at the carrier frequency will be

displayed. If **RF Input Range** is set to **Auto**, and **Input Atten** is changed, **RF Input Range** is switched to **Manual**.

NOTE

The **Max Total Pwr** and **Input Atten** settings are coupled together. When you switch to a different measurement, the **Max Total Pwr** is kept constant, but the **Input Atten** may change if the two measurements have different mixer margins. Thus, you can directly set the transmitter tester input attenuation, or you can set it indirectly by specifying the maximum expected power at the UUT (**Max Total Pwr** setting).

- **Ext Atten** - To enter the external attenuator setting for either a base station or mobile station. This will allow the instrument to display the measurement results referred to the output of the UUT (Unit Under Test).
- **IF Align Signal** - This key has effect only when **Input Port** is set to **IF Align**. When **IF Align** is activated, the RF path is switched to bring in the same alignment signal that is automatically switched in to perform many alignments. This selection will allow manual adjustment of the alignment signal for diagnostic purposes:
 - **Signal Rate** - The signal is modulated by a digital sequence that can be set to 1 of 13 positions (rate 0 through 12) to cause the comb spacing (or pulse timing) to widen or narrow. The key reports the comb spacing for a given rate (0 to 12) in “kHz”.
 - **Signal Amptd** - This is the DAC control that changes the amplitude of the signal. It is a 12 bit (0 to 4095) DAC. A higher DAC number will raise the signal amplitude.
 - **Signal Type** - This can be **CW** (a tone that appears in the center of the IF), **Comb**, or **Pulse**.

Input Default Settings	
Input Port	RF
RF Input Range	Auto
Max Total Power	-15.00 dBm
Input Atten	0.00 dB
Ext Atten Mobile	0.00 dB
Ext Atten Base	0.00 dB
IF Align Signal Rate	0 (= 468.75 kHz)
IF Align Signal Amptd	DAC 500
IF Align Signal Type	CW

Trigger

The **Trigger** key accesses the mode setup menu for the following trigger source menus:

- **RF Burst**
- **Video (IF Envlp)**
- **Ext Front**
- **Ext Rear**

Pressing one of the trigger source menu keys will access the trigger mode setup menu. This menu is used to set the **Delay**, **Level**, and **Slope** for each trigger source. Note that the actual trigger source is selected separately for each measurement (under the **Meas Setup** key).

Delay - For trigger delay use positive values. For pre-trigger use negative values.

Level - For the **RF Burst** selection, the level is relative to the peak level of the RF signal. For the **Video** selection, the level is the value, in dBm at the RF input, that will cause the trigger. For the **Ext Front** and **Ext Rear** selections, the level range is -5 to +5 volts.

Slope Pos Neg - Choose to trigger off of the leading edge (**Pos**) or the trailing edge (**Neg**) of the burst.

Other keys accessed under the **Trigger** key:

- **Trig Holdoff** - sets the period of time before the next trigger can occur.
- **Auto Trig** - acts as a trigger timeout. If no trigger occurs by the specified time, a trigger is automatically generated.
- **Frame Timer** - accesses the menu to manually control the frame timer:

Period - sets the period of the frame clock

Offset - sets a one-time phase adjustment of the frame clock

Reset Offset - resets the display of offset key to 0

Sync Source - selects the source used to sync the frame timer

Trigger Default Settings	
RF Burst	
Delay	0.000 s
Peak Level	-6.00 dB
Slope	Pos
Video	
Delay	0.000 s
Level	-6.00 dBm
Slope	Pos
Ext Front	
Delay	0.000 s
Level	2.00 V
Slope	Pos
Ext Rear	
Delay	0.000 s
Level	2.00 V
Slope	Pos
Trig Holdoff	0.000 s
Auto Trig	100.0 ms Off
Frame Timer	
Period	250 μ s
Offset	0.000 s
Reset Offset	Display
Sync Source	Off

Demod

- **Sync Type** - selects the type of synchronization used for the demodulation.
 - **Even Sec** - synchronizes to the internal frame timer that has been synchronized to an even second clock input. The frame timer has a 26.6667 ms period. This input signal is connected to the rear-panel TRIGGER IN connector.
 - **Pilot Seq** - synchronizes to the pilot sequence on the RF channel. As this does not provide an absolute time reference, the measured time offset value will not be valid.
 - **Ext Front** - directly synchronizes to an external signal connected to the front-panel EXT TRIGGER INPUT connector.
 - **Ext Rear** - directly synchronizes to an external signal connected to the rear-panel TRIGGER IN connector.
 - **None** - no synchronization is used.

- **PN Offset**- Used to enter the PN offset of the base station being tested. This allows correct time offset values to be determined. This setting is not applicable when **Sync Type** is set to **Pilot Seq.**
- **RF Carrier** - Select **Single** if there is a single RF carrier present at the RF Input. Select **Multi** if there is more than one carrier present at the RF Input; which rejects the upper and lower adjacent channels for the modulation accuracy and code domain measurements.

Demod Default Settings	
Sync Type	Even Sec
PN Offset	0×64 [chips]
RF Carrier	Single

Changing the Frequency Channel

After selecting the desired mode setup, you will need to select the desired center frequency and PN offset. The selections made here will apply to all measurements in the mode. Press the **Frequency Channel** key to access the following softkeys:

- **Center Freq** - This is the current instrument center frequency. Use this key to input a frequency that corresponds to the desired RF channel to be measured.
- **PN Offset** - Used to enter the PN offset of the base station being tested. This allows correct time offset values to be determined as time offset is defined relative to the PN offset. The range is 0 to 511×64 [chips]. This setting is not applicable when **Sync Type** is set to **Pilot Seq**. It is duplicated in **Demod** under **Mode Setup** key, for the modulation accuracy and code domain measurements.

Function	Factory Default Setting
Center Frequency	1.00000 GHz
PN Offset	0×64 [chips]

cdmaOne Measurement Key Flow

The key flow diagrams, shown in a hierarchical manner on the following pages, will help the user to grasp the overall functional relationships for the front-panel keys and the softkeys displayed at the extreme right side of the screen. The diagrams are:

“Mode Setup / Frequency Channel Key Flow (1 of 2)” on page 21

“Channel Power Measurement Key Flow” on page 23

“Modulation Accuracy (Rho) Measurement Key Flow” on page 24

“Code Domain Measurement Key Flow” on page 25

“Spur Close Measurement Key Flow” on page 26

“Spectrum (Freq Domain) Measurement Key Flow (1 of 3)” on page 27

“Waveform (Time Domain) Measurement Key Flow (1 of 2)” on page 30

“ACPR Measurement Key Flow” on page 32

Use these flow diagrams as follows:

- There are some basic conventions:

Meas Setup An oval represents one of the front-panel keys.

EVM This box represents one of the softkeys displayed.

<for EVM> This represents an explanatory description on its specific key.

Avg Number 10 On | Off This box represents one of the default condition softkeys displayed. Default conditions are shown as much as possible with underlined parameters or values displayed on those softkey labels.

- Follow the measurement diagram from left to right and top to bottom.
- A single softkey may allow multiple choices. For example; the **Device** softkey reveals two choices, **Base** or **Mobile**. The underlined choice is the current state of the instrument. To change choices, press the softkey one time.
- When entering a numeric value of **Frequency**, for example, use the numeric keypad and terminate the entry with the appropriate unit selection from the softkeys displayed.
- When entering a numeric value of **Slot (Std)**, for example, use the numeric keypad and terminate with the **Enter** front-panel key.
- Instead of using the numeric keypad to enter a value, it may be easier to use the RPG knob or **Up/Down** keys.

Figure 2-1 Mode Setup / Frequency Channel Key Flow (1 of 2)

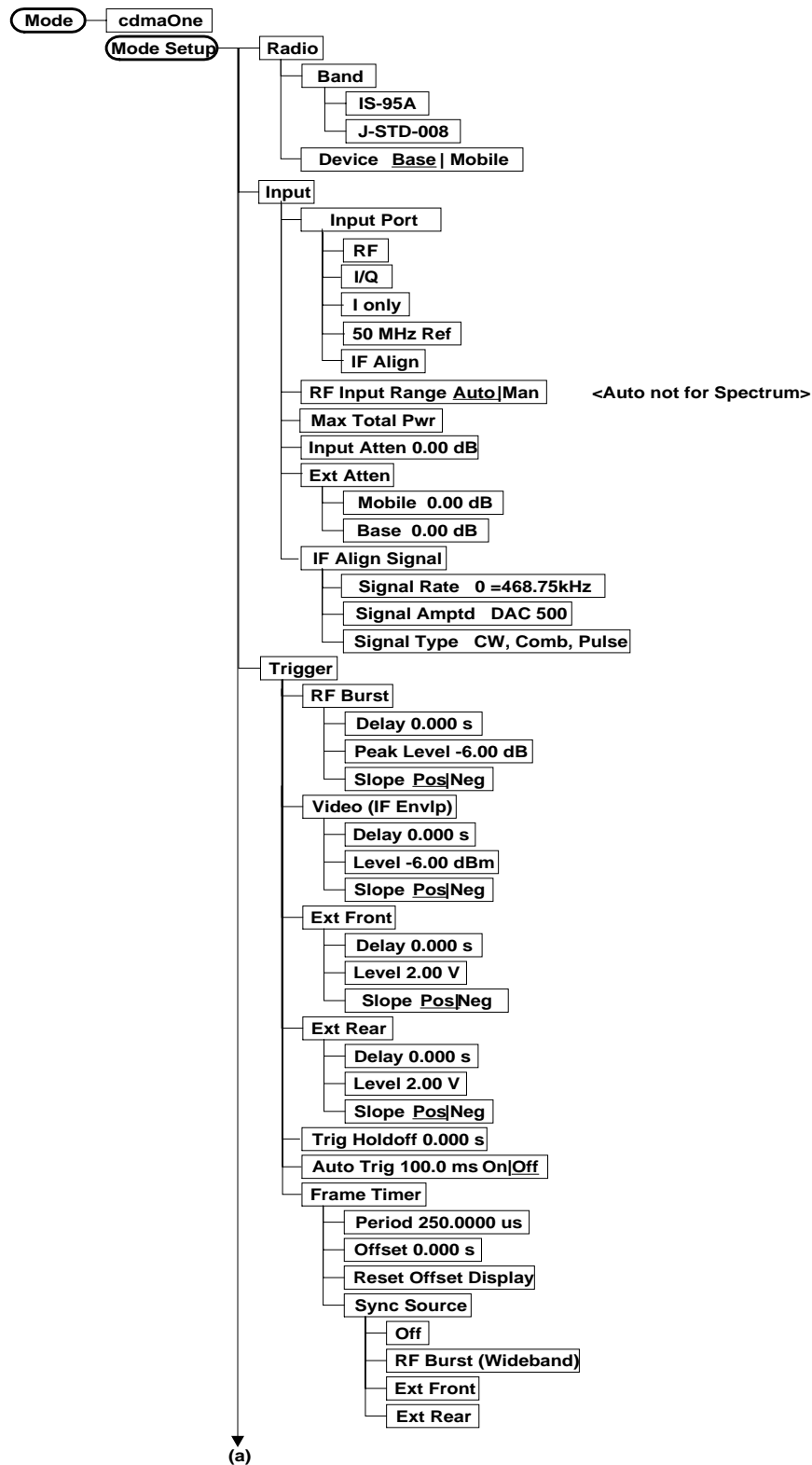

Figure 2-2 Mode Setup / Frequency Channel Key Flow (2 of 2)

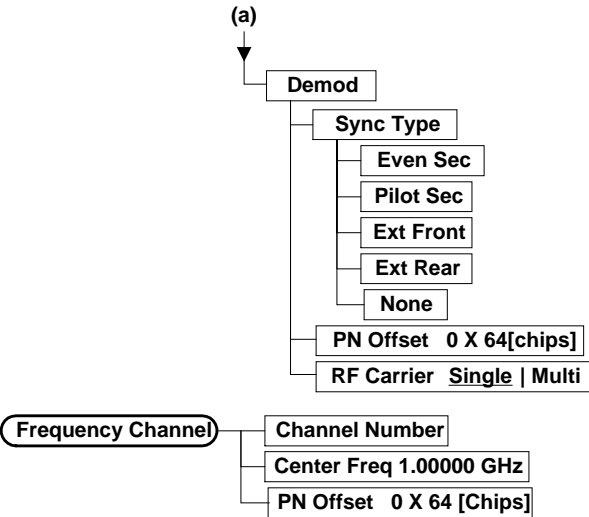

Figure 2-3 Channel Power Measurement Key Flow

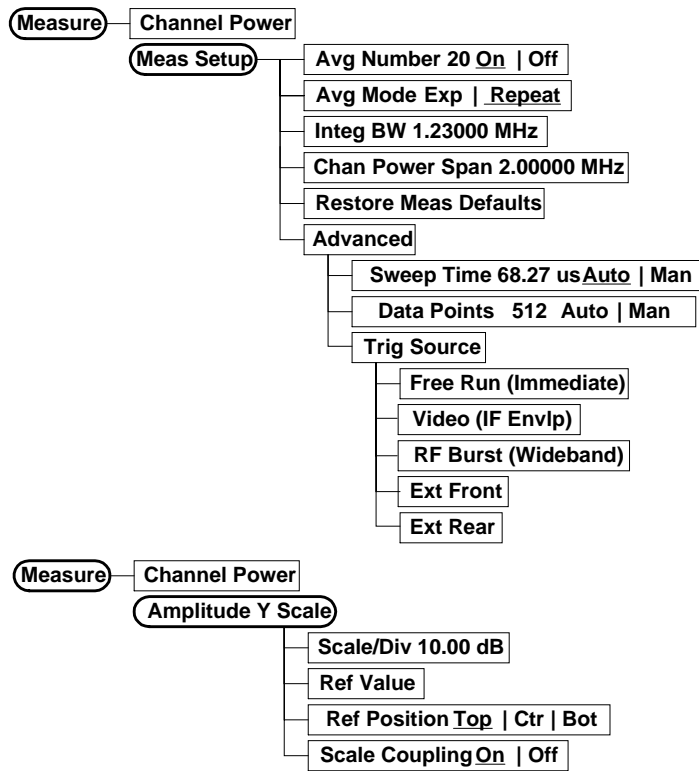

Figure 2-4 Modulation Accuracy (Rho) Measurement Key Flow

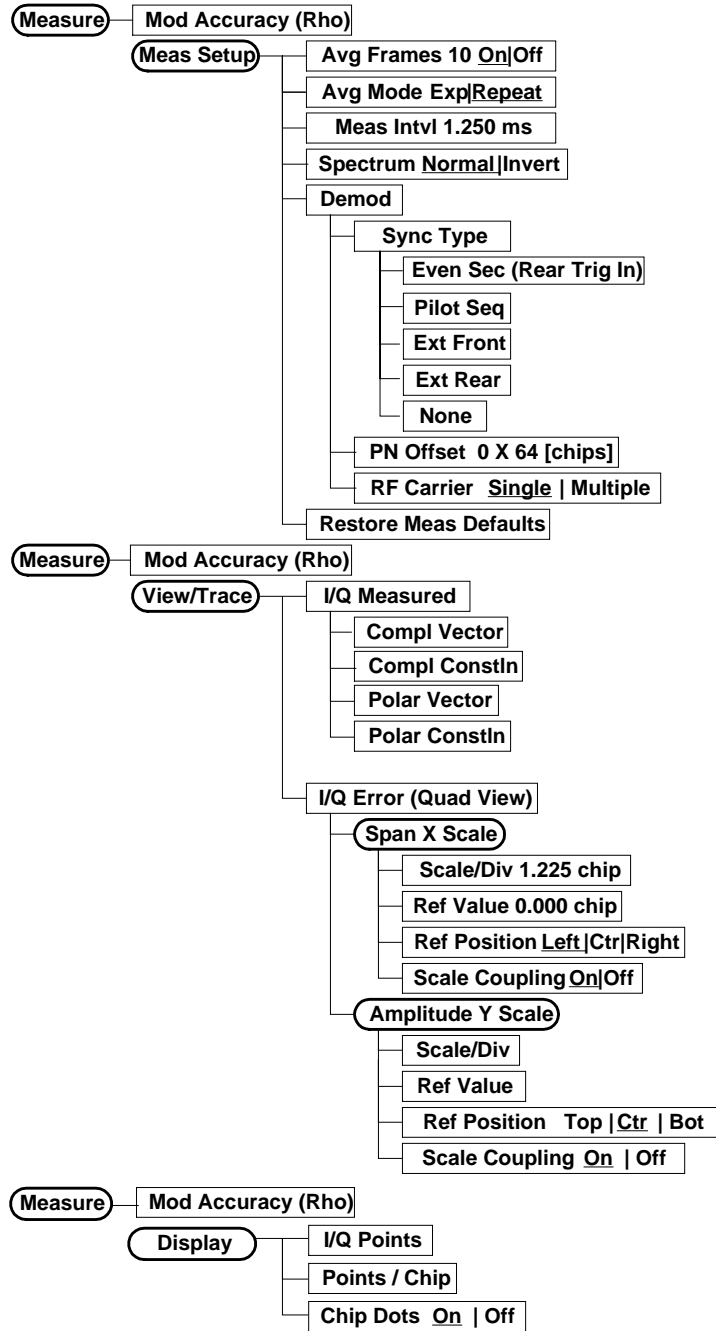

Figure 2-5 Code Domain Measurement Key Flow

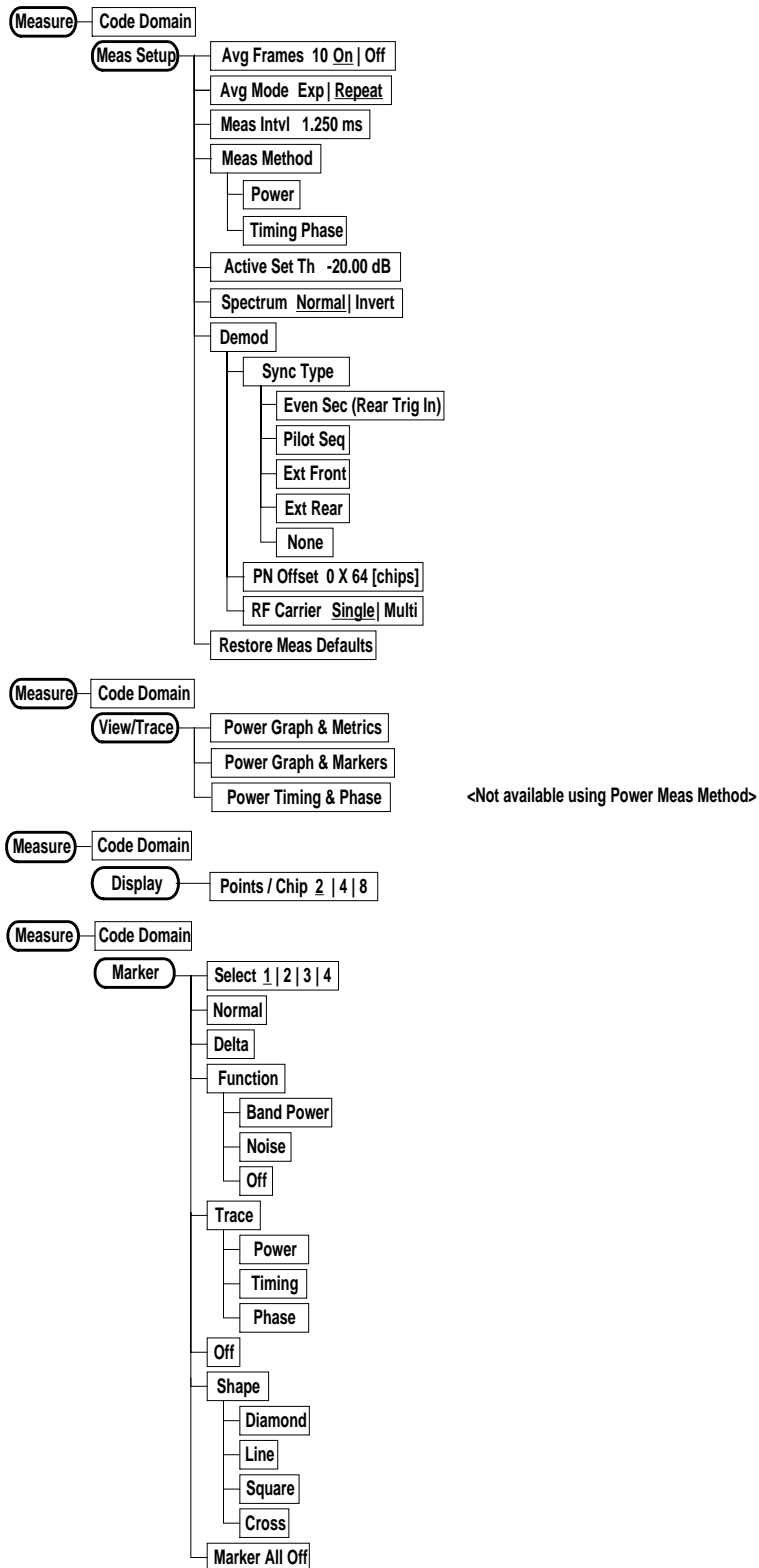

Figure 2-6 Spur Close Measurement Key Flow

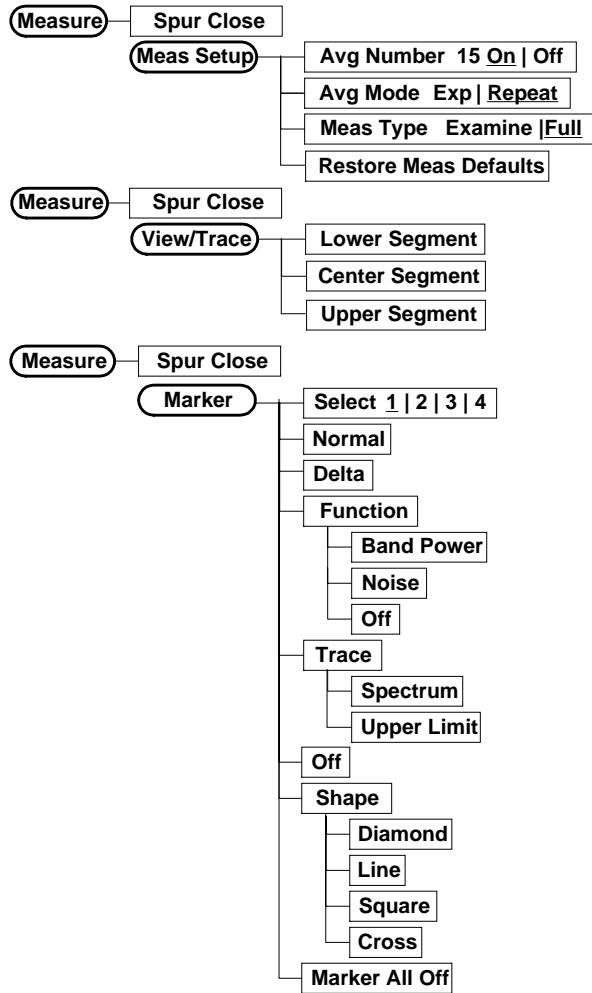

Figure 2-7 Spectrum (Freq Domain) Measurement Key Flow (1 of 3)

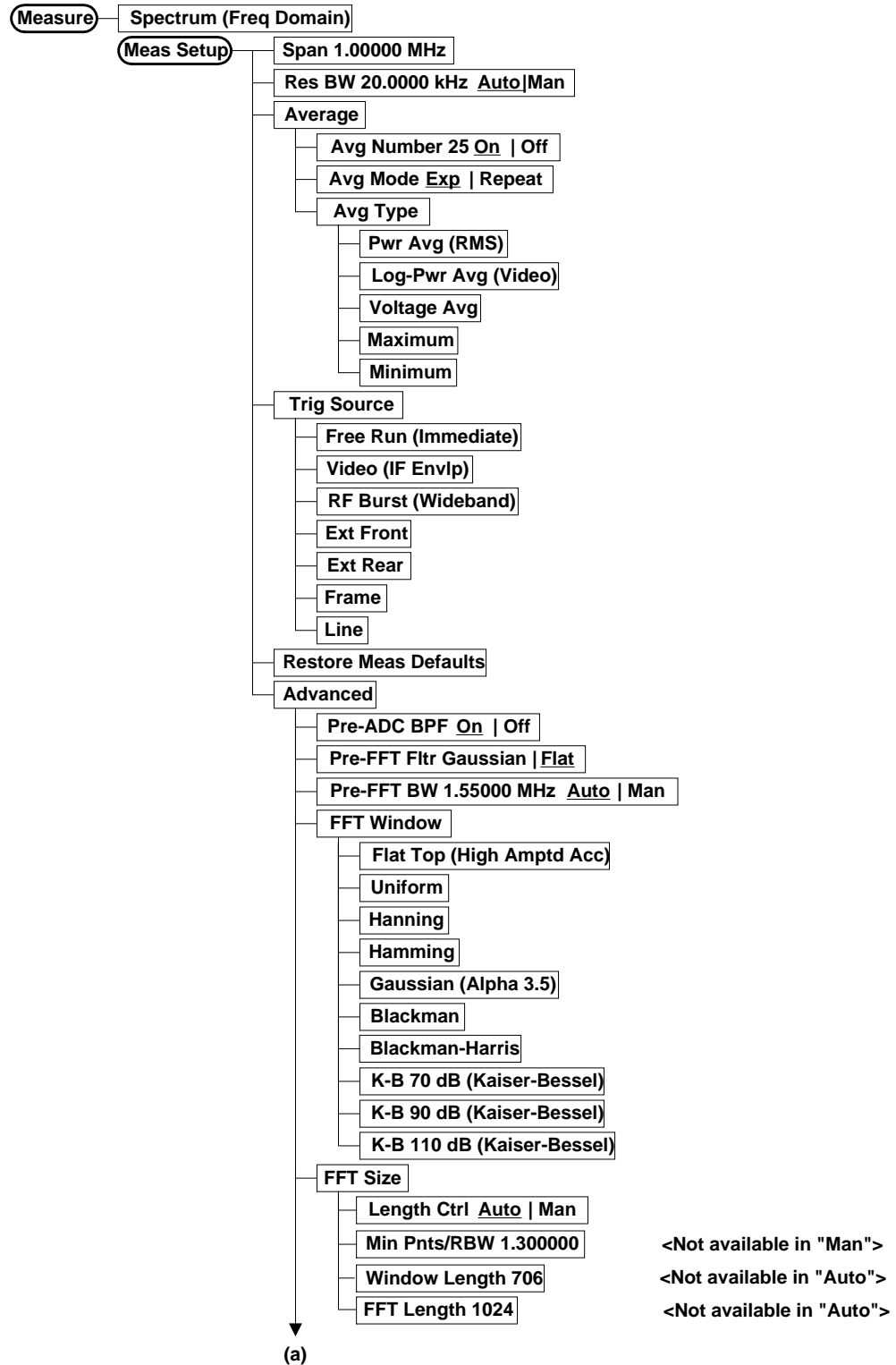

Figure 2-8 Spectrum (Freq Domain) Measurement Key Flow (2 of 3)

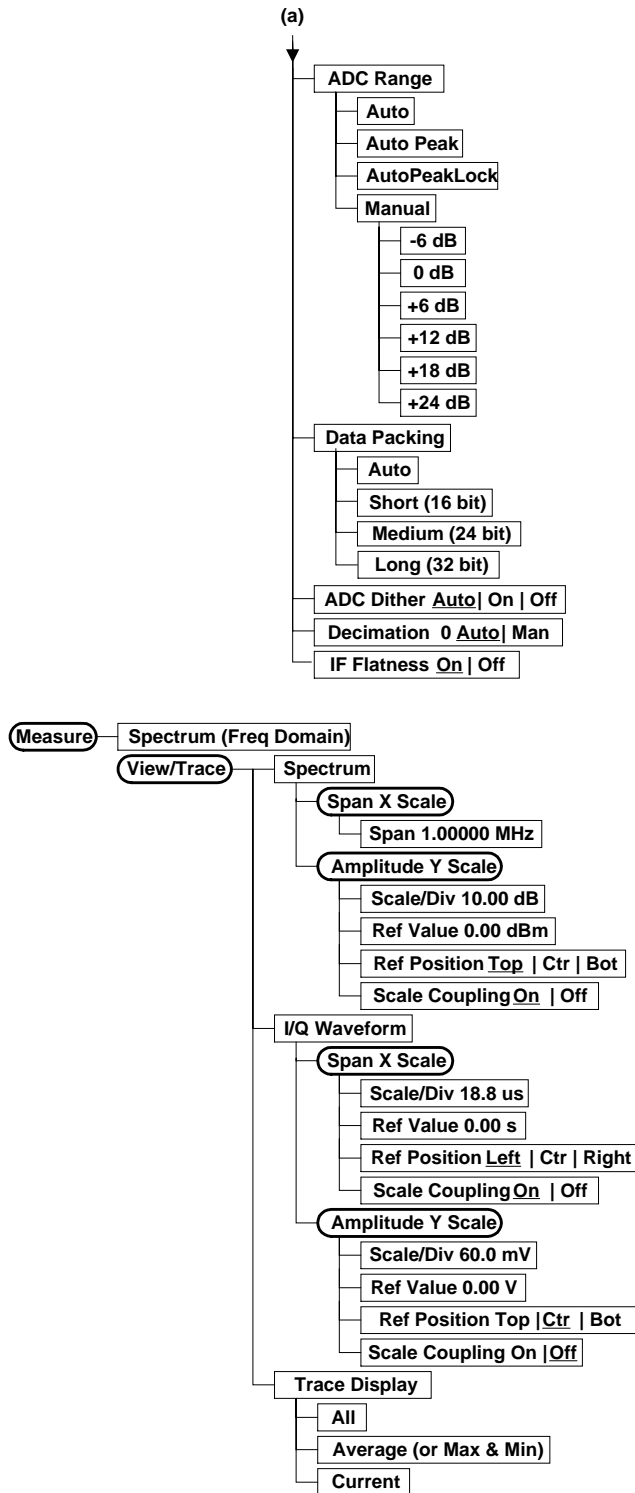

Figure 2-9 Spectrum (Freq Domain) Measurement Key Flow (3 of 3)

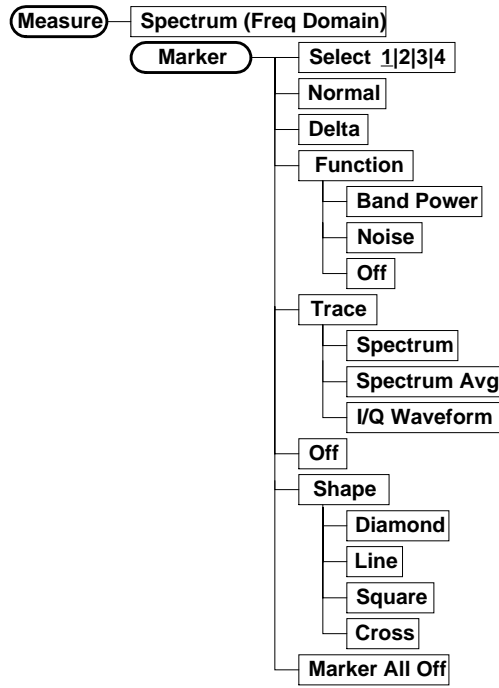

Figure 2-10 Waveform (Time Domain) Measurement Key Flow (1 of 2)

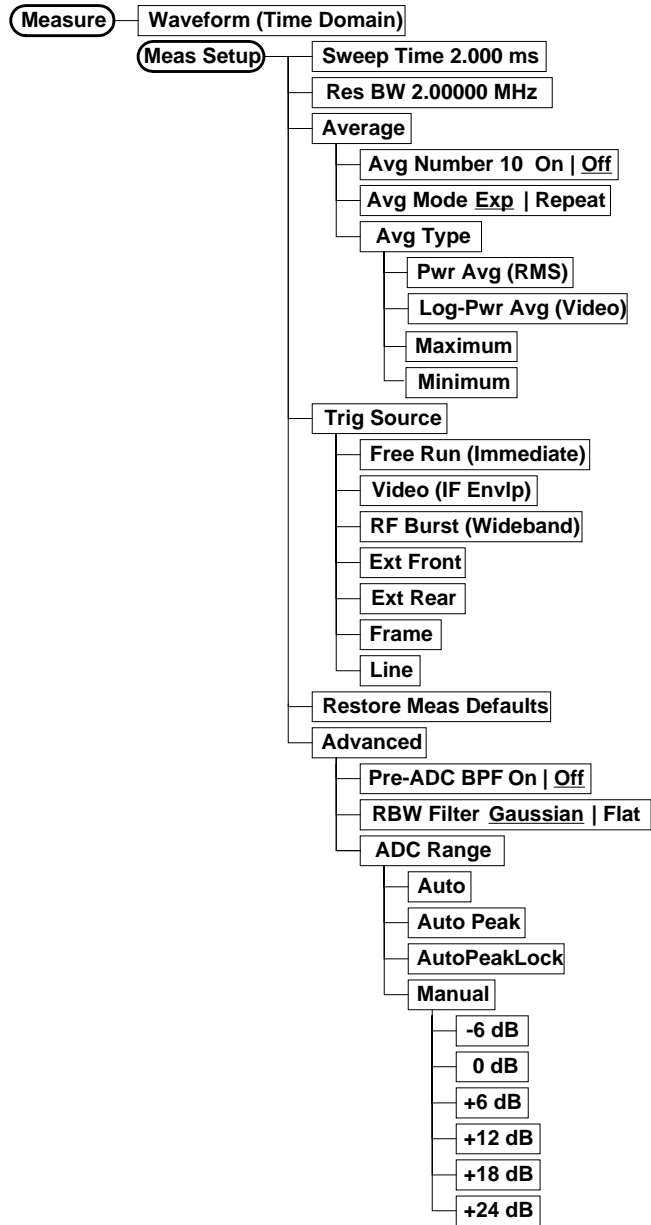

Figure 2-11 Waveform (Time Domain) Measurement Key Flow (2 of 2)

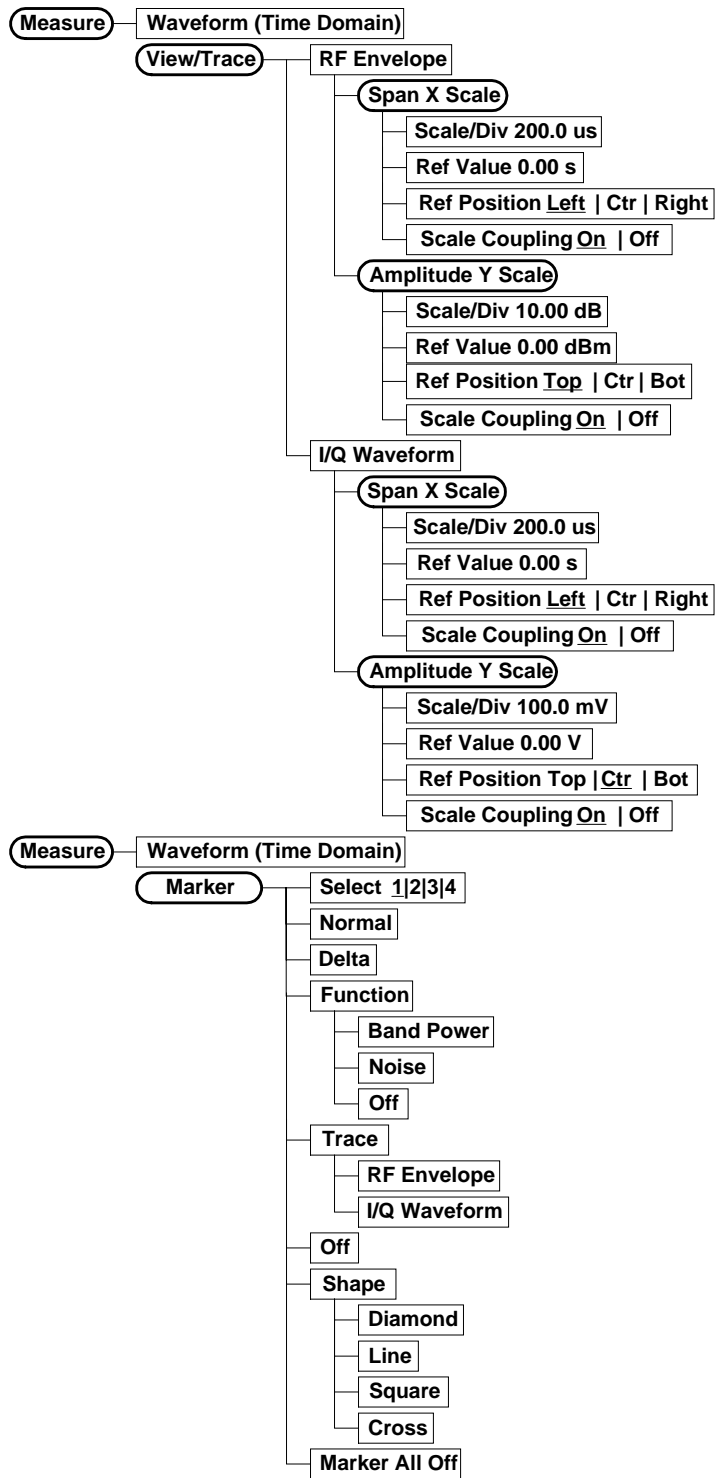
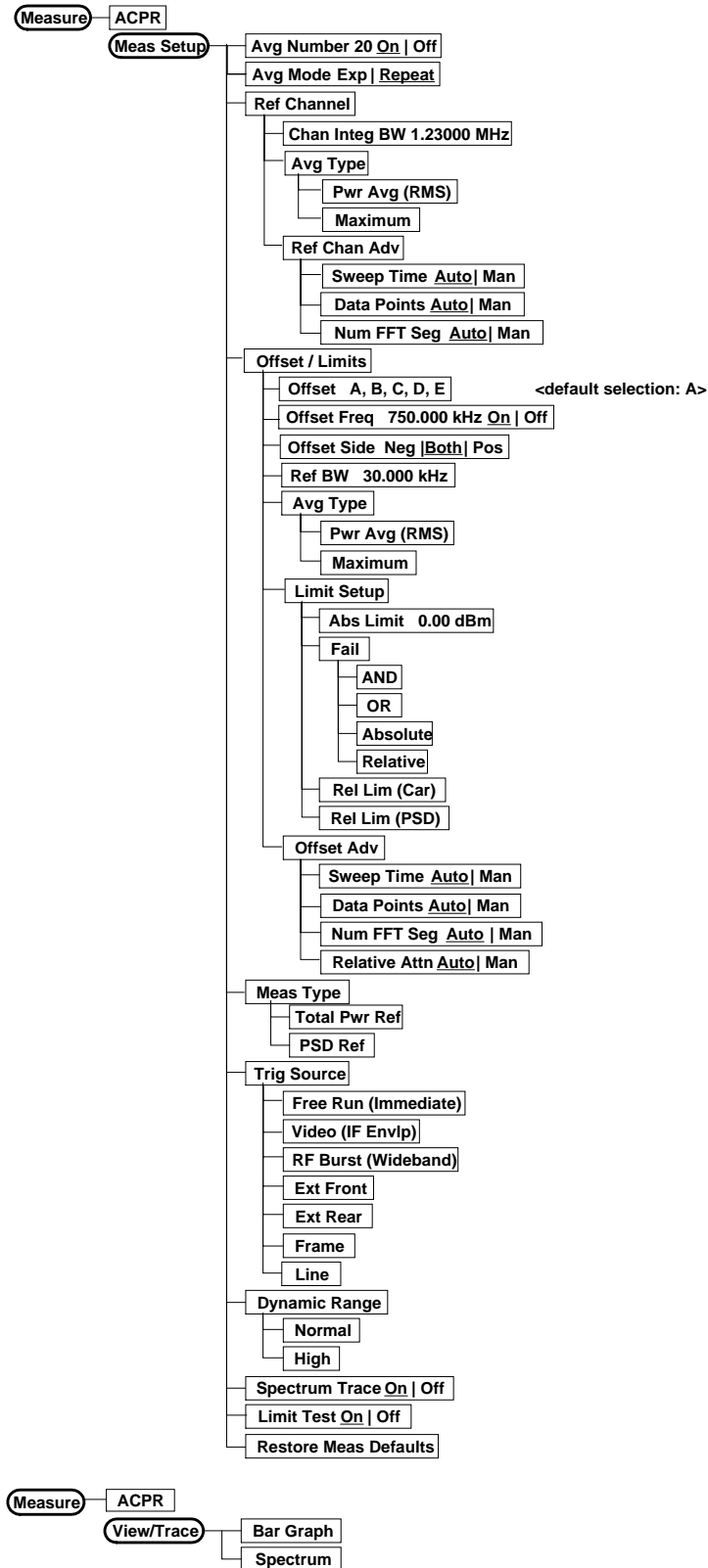

Figure 2-12 ACPR Measurement Key Flow



Installing Optional Measurement Personalities

When you **Install** a measurement personality, you follow a two step process.

1. Install the measurement personality firmware into the instrument. (See the supplied installation instructions.)
2. Enter a license key number to enable the measurement personality. (Refer to the “License Key Numbers” section below.)

Adding additional measurement personalities requires purchasing a retrofit kit for the desired option. The retrofit kit contains the measurement personality firmware. A license key certificate is also included in the kit. It documents the license key number that is for your specific option and instrument serial number. Installation instructions are included with the retrofit kit.

The installation instructions require you to know three pieces of information about your instrument: the amount of memory installed, the Host ID, and the instrument serial number.

Required information:	Key Path:
Instrument Memory: _____	System, File System (the amount of memory in your instrument will be the sum of the <i>Used</i> memory and the <i>Free</i> memory)
Host ID: _____	System, Show System, Host ID
Instrument Serial Number: _____	System, Show System, Serial Number

The **Exit Main Firmware** key is used during the firmware installation process. This key is only for use when you want to update firmware using a LAN connection. The **Exit Main Firmware** key halts the operation of the instrument firmware so you can install an updated version of firmware using a LAN connection. Instructions for loading future firmware updates are available at the following URL:

www.agilent.com/find/vsa/

Available Personality Options

The option designation consists of three characters, as shown in the **Option** column of the table below.

Available Personality Options ^a	Option
GSM measurement personality	BAH
EDGE (with GSM) measurement personality ^b	202
cdmaOne measurement personality	BAC
NADC, PDC measurement personalities	BAE
iDEN measurement personality	HN1
W-CDMA measurement personality	BAF
cdma2000 measurement personality	B78

a. Available as of the print date of this guide.

b. For instruments that already have Option BAH licensed, order E4406AU Option 252 to add EDGE (with GSM).

License Key Numbers

Measurement personalities purchased with your instrument have been installed and enabled at the factory. You will receive a unique license key number with every measurement personality purchased. The license key number is a hexadecimal number that is for your specific measurement personality and instrument serial number. It enables you to install, or reactivate that particular personality.

Follow these steps to display the unique license key number for the measurement personality that is installed in your instrument:

1. Press **System, Install, Choose Option**. The **Choose Option** key accesses the alpha editor. Use the alpha editor to enter letters (upper-case) and the front-panel numeric keys to enter digits for a personality option that is already installed in the instrument.
2. Press the **Done** key on the alpha editor menu. The unique license key number for your instrument will now appear on the **License Key** softkey.

You will want to keep a copy of your license key number in a secure location. Please enter your license key numbers below for future reference. If you should lose your license key number, call your nearest Agilent Technologies service or sales office for assistance.

License Key Numbers for Instrument with Serial # _____	
For Option _____	the license key number is _____
For Option _____	the license key number is _____
For Option _____	the license key number is _____
For Option _____	the license key number is _____
For Option _____	the license key number is _____
For Option _____	the license key number is _____

If you purchase an option later, you will receive a certificate that indicates the unique license key number that you will need to install that option on your particular serial number instrument.

NOTE

You will need to enter a license key number only if you purchase an additional measurement personality at a later date, or if you want to reactivate a measurement personality that has been deactivated.

Installing a License Key Number

NOTE

Follow this procedure to reinstall a license key number which has been deleted during the uninstall process, or lost due to a memory failure.

To install a license key number for the selected option, use the following procedure:

1. Press **System, Install, Choose Option**. The **Choose Option** key accesses the alpha editor menu. Use the alpha editor to enter letters (upper-case) and the front-panel numeric keys to enter numbers for the option designation. Then press the **Done** key. As you enter the option, you will see your entry in the active function area of the display.

Note: that you must already have entered the license key for the GSM option BAH before you can enter the license key for the EDGE retrofit option 252.

2. Press **License Key**. Use the alpha editor to enter letters and the front-panel numeric keys to enter digits. You will see your entry in the active function area of the display. When you have completed entering the license key number, press the **Done** key.
3. Press the **Install Now** key after you have entered the personality option number and the license key number. On some instruments, a message may appear in the function area of the display which reads, "Insert disk and power cycle the instrument". Disregard this message. If you want to proceed with the installation, press the **Yes** key and cycle the instrument power off and then on. Press the **No** key if you wish to cancel the installation process.

Using the Uninstall Key

The following procedure removes the license key number for the selected option. This will make the option unavailable for use, and the message “Application Not Licensed” will appear in the Status/Info bar at the bottom of the display. Please write down the 12-digit license key number for the option before proceeding. If that measurement personality is to be used at a later date you will need the license key number to reactivate the personality firmware.

NOTE

Using the **Uninstall** key does not remove the personality from the instrument memory, and does not free memory to be available to install another option. If you need to free memory to install another option, refer to the instructions for loading firmware updates located at the URL: www.agilent.com/find/vsa/

1. Press **System, More(1 of 3), More(2 of 3), Uninstall, Choose Option**. Pressing the **Choose Option** key will activate the alpha editor menu. Use the alpha editor to enter the letters (upper-case) and the front-panel numeric keyboard to enter the digits (if required) for the option, then press the **Done** key. As you enter the option, you will see your entry in the active function area of the display.
2. Press the **Uninstall Now** key after you have entered the personality option. Press the **Yes** key if you want to continue the uninstall process. Press the **No** key to cancel the uninstall process.
3. Cycle the instrument power off and then on to complete the uninstall process.

Setting Up the cdmaOne Mode
Installing Optional Measurement Personalities

3 Making cdmaOne Measurements

cdmaOne Measurements

Once in the cdmaOne mode, the following measurements are available by pressing the **Measure** key:

- “Making the Channel Power Measurement” on page 45
- “Making the Modulation Accuracy (Rho) Measurement” on page 50
- “Making the Code Domain Measurement (Base Station Only)” on page 56
- “Making the Spur Close Measurement” on page 61
- “Making the Spectrum (Frequency Domain) Measurement” on page 67
- “Making the Waveform (Time Domain) Measurement” on page 75
- “Making the Adjacent Channel Power Ratio (ACPR) Measurement” on page 82

These are referred to as one-button measurements. When you press the key to select the measurement it will become the active measurement, using settings and a display unique to that measurement. The measurement settings default values used for the selected standard. Data acquisitions will automatically begin provided trigger requirements are met.

Preparing for Measurements

If you want to set the cdmaOne mode to a known, factory default state, press **Preset**. This will preset the mode setup and all of the measurements to the factory default parameters. Note that **Preset** does not switch modes.

To preset only the settings that are specific to the selected measurement, press **Meas Setup, More, Restore Meas Defaults**. This will set the measurement setup parameters, for the currently selected measurement only, to the factory defaults.

Initial Setup

Before making a measurement, make sure the mode setup and frequency channel parameters are set to the desired settings. Refer to the sections “[Changing the Mode Setup](#)” and “[Changing the Frequency Channel](#)” in the previous chapter.

How to Make a Measurement

Follow the three-step process shown in the table below:

Step	Primary Key	Setup Keys	Related Keys
1. Select & setup a mode	Mode	Mode Setup, Input, Frequency Channel	System
2. Select & setup a measurement	Measure	Meas Setup	Meas Control, Restart
3. Select & setup view	View/Trace	Span X Scale, Amplitude Y Scale, Display, Next Window, Zoom	File, Save, Print, Print Setup, Marker, Search

Measure Control

The **Meas Control** front panel menu key controls processes that affect the running of the current measurement.

- **Measure key.** Press **Meas Control, Measure** (not to be confused with the front panel **Measure** key which has a different function) to toggle between **Single** and **Cont** (for continuous) measurement states. When set to **Single**, the measurement will continue until it has reached the specified number of averages set by the average counter. When set to **Cont**, the measurement will run continuously, and perform averaging according to the current average type (repeat or exponential). The default setting is continuous.
- **Pause key.** Press **Meas Control, Pause** to pause the current measurement. Once toggled, the label of the **Pause** key changes to read **Resume**; the **Resume** key, once pressed, continues the active measurement from the point at which it was paused.
- **Restart key.** Press **Restart** front panel key to repeat the current measurement from the beginning, while retaining the current measurement settings.

Measurement Setup

The **Meas Setup** key accesses features that enable you to adjust parameters of the current measurement, such as resolution bandwidth. You will also use the **Meas Setup** menu to access **Average, Trig Source,** and **Advanced** measure setup feature menus.

The following measure setup features can be used with many or all measurements:

- **Res BW key.** Press **Meas Setup, Res BW** to change the resolution of a given measurement. Selection of a narrower bandwidth will result in a longer data acquisition time.
- **Restore Meas Defaults key.** Press **Meas Setup, More, Restore Meas Defaults** to preset only the settings that are specific to the selected measurement. This will set the measure setup parameters, for the currently selected measurement only, to the factory defaults.

Averaging

Selecting one of the averaging keys in the **Meas Setup** menu will allow you to modify the number, average mode, and type of averaging you use for the currently selected measurement.

- **Avg Number** - will allow you to change the number of N averages to be made.
- **Avg Mode** - will allow you to choose either exponential or repeat averaging. This selection only effects the averaging after the number of N averages is reached (set using **Avg Number**).
 - **Normal averaging**: Normal (linear) averaging is always used until the specified number of N averages is reached. When **Measure** is set at **Single**, data acquisitions are stopped when the number of averages is reached - thus **Avg Mode** has no effect on single measurements.
 - **Exponential averaging**: When **Measure** is set at **Cont**, data acquisitions will continue indefinitely. After N averages, exponential averaging is used with a weighting factor of N (the displayed average count stops at N). Exponential averaging weights new data more than old data, which allows tracking of slow-changing signals. The weighting factor N is set using **Avg Number**.
 - **Repeat averaging**: When **Measure** is set at **Cont**, data acquisitions will continue indefinitely. After N averages is reached, all previous result data is cleared and the average count is set back to 1. This is equivalent to being in **Measure Single** and pressing the **Restart** key each time the single measurement finishes.

Trigger Source

Changing the **Trig Source** alters the trigger source for the selected measurement only. Not all of the selections are available for all measurements. Many CDMA measurements do not require a trigger. These do not have a Trig Source key. Note that the **RF Burst**, **Video (IF Envlp)**, **Ext Front**, and **Ext Rear** menu keys found in the **Trigger** menu enable you to change settings to modify the delay, level, and slope for each of these trigger sources. Choose one of the following trigger sources:

- **Free Run (Immediate)** - the trigger occurs at the time the data is requested, completely asynchronous to the RF or IF signal.
- **Video (IF Envlp)** - an internal IF envelope trigger. It triggers on an absolute threshold level of the signal passed by the IF.
- **RF Burst (Wideband)** - an internal wideband RF burst trigger that has an automatic level control for burst signals. It triggers on a level that is relative to the peak of the signal passed by the RF (12 MHz bandwidth).
- **Ext Front** - activates the front panel **EXT TRIGGER INPUT**. The external trigger must be a signal between -5 and $+5$ volts.
- **Ext Rear** - activates the rear panel **TRIGGER IN**. The external trigger must be a signal between -5 and $+5$ volts.
- **Trig Holdoff** - sets the minimum time after a trigger, before a re-trigger can occur.
- **Frame** - uses the internal frame clock to generate a trigger signal. The clock parameters are controlled under the **Mode Setup** key or the measurement firmware, not both. See the specific measurement for details.
- **Line** - activates an internal line trigger. Sweep triggers occur at intervals synchronized to the line frequency.

Rear panel **TRIGGER 1 OUT** and **TRIGGER 2 OUT** connectors are coupled to the selected trigger source. These trigger outputs are always on the rising edge with a pulse width of at least $1 \mu\text{s}$.

Making the Channel Power Measurement

Purpose

The Channel Power measurement is a common test used in the wireless industry to measure the total transmitted power of a radio within a defined frequency channel. This procedure measures the total power within the defined channel. This measurement is applied to design, characterize, evaluate, and verify transmitters and its components or devices for base stations and mobile stations.

Measurement Method

The Channel Power measurement reports the total power within the channel bandwidth. The transmitter tester acquires a number of points representing the input signal in the time domain. It transforms this information into the frequency domain using FFT and then calculates the channel power. The effective resolution bandwidth of the frequency domain trace is proportional to the number of points acquired for FFT. The fastest FFT process is achieved using a number of acquired points that is a power of 2 (for example: 64, 128, 512). Since the measurement is optimized for speed and accuracy, you are permitted to change only the number of acquired data points in powers of 2, not the actual resolution bandwidth. However, if absolute sweep time is required, sweep time can be changed to the user's specified time at the expense of reduced speed. At no time will both sweep time and data points be set to manual because of conflicting parameter settings. This flexibility is available through the **Advanced** menu of the channel power measurement.

To improve repeatability, you can increase either the number of averages or the number of data points with longer time record length. The channel power graph is shown in the graph window and the absolute channel power in dBm and the mean power spectral density in dBm/Hz are shown in the text window.

Making the Measurement

NOTE

The factory default settings provide a good starting point. You will likely want to change some of the settings. Press **Meas Setup, More (1 of 2), Restore Meas Defaults** at any time to return all parameters for the current measurement to their default settings.

Select the desired center frequency.

Press **Measure, Channel Power** to immediately make Channel Power the active measurement.

To change any of the measurement parameters from the factory default values, refer to the “Changing the Measurement Setup” section.

Results

The following figure shows an example result of channel power measurements. The channel power graph is shown in the graph window. The absolute channel power and its mean power spectral density are shown in the text window.

Figure 3-1 Channel Power Measurement

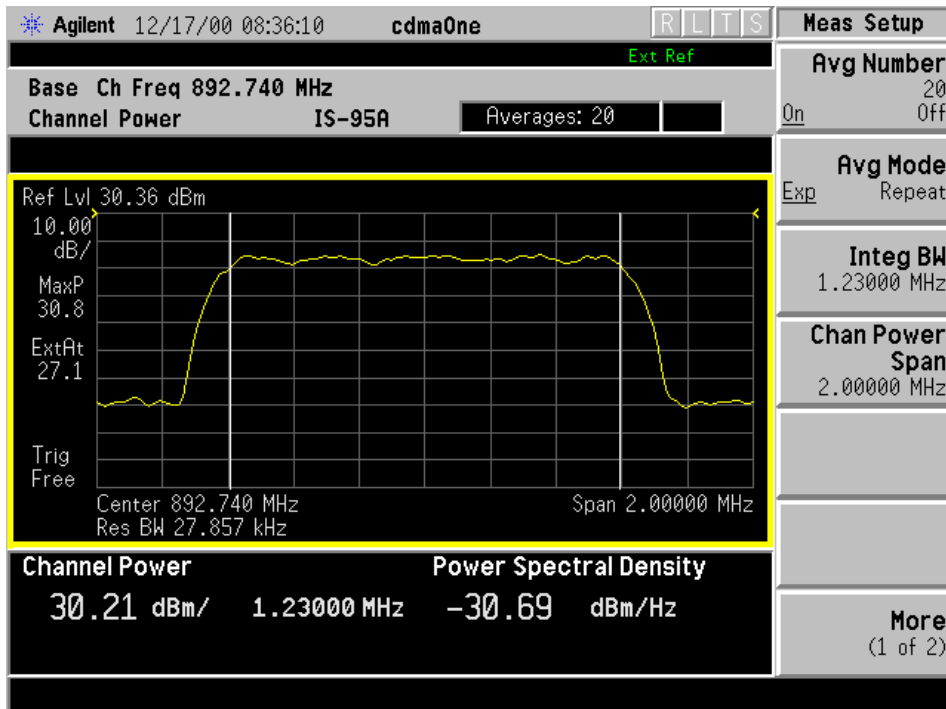

Changing the Measurement Setup

The next table shows the factory default settings for channel power measurements.

Table 3-1 Channel Power Measurement Defaults

Measurement Parameter	Factory Default Condition
Meas Setup:	
Avg Number	20 On
Avg Mode	Repeat
Integ BW	1.23000 MHz
Chan Power Span	2.00000 MHz
Advanced	
Sweep Time	68.27 μ s Auto
Data Points	512 Auto
Trig Source	Free Run (Immediate)

NOTE

Parameters under the **Advanced** key seldom need to be changed. Any changes from the factory default values may result in invalid measurement data.

Make sure the **Channel Power** measurement is selected under the **Measure** menu. The **Meas Setup** key accesses the menu which allows you to modify the average number and average mode for this measurement.

The following parameters can be changed according to your measurement requirement:

- **Integ BW** - Allows you to specify the integration bandwidth in which the power is measured. The range is 1.000 kHz to 10.0000 MHz with 1 or 10 Hz resolution.
- **Chan Pwr Span** - Allows you to set the frequency span for the channel power measurement. The range is 1.626 to 10 times the integration bandwidth but limited up to 10 MHz with 1 or 10 Hz resolution. This span is used for the current **Integ BW** setting. Since **Chan Pwr Span** is coupled to **Integ BW**, if you change the integration bandwidth setting, the channel power span setting changes by a proportional amount until a limit value is reached.

In addition, the following parameters for channel power measurements can be modified by pressing the **Advanced** key:

- **Sweep Time** - Allows you to manually change the sweep time and also to toggle the sweep time control between **Auto** and **Man** (manual). The range is 1.000 μ s to 50.00 ms with 1 or 10 μ s resolution. The default setting is 68.27 μ s and **Auto**.
- **Data Points** - Allows you to select the number of data points. The automatic mode chooses the optimum number of points for the fastest measurement time with acceptable repeatability. The minimum number of points that could be used is determined by the sweep time and the sampling rate. You can increase the length of the measured time record (capture more of the burst) by increasing the number of points, but the measurement will take longer.
- **Res BW** - Shows information on the resolution bandwidth derived from the sweep time.
- **Trig Source** - Allows you to choose the trigger source from **Free Run** (Immediate), **Video (IF Envl)**, **RF Burst (Wideband)**, **Ext Front** or **Ext Rear**.

Changing the Display

The **Amplitude Y Scale** key accesses the menu to set the desired vertical scale and associated settings.

- **Scale/Div** - Allows you to enter a numeric value to change the vertical display sensitivity. The range is 0.10 to 20.00 dB with 0.01 dB resolution. The default setting is 10.00 dB, however, since **Scale Coupling** is defaulted to **On**, this value is automatically determined by the measurement result.
- **Ref Value** - Allows you to enter a numeric value to change the absolute power value as the display reference. The range is 0.00 to 250.00 dBm with 0.01 dB resolution, however, since **Scale Coupling** is defaulted to **On**, this value is automatically determined by the measurement result.
- **Ref Position** - Allows you to set the display reference position to either **Top**, **Ctr** (center), or **Bot** (bottom). The default setting is **Top**.
- **Scale Coupling** - Allows you to toggle the scale coupling function between **On** and **Off**. The default setting is **On**. This function automatically determines the scale per division and reference values by the measurement results.

Troubleshooting Hints

If an external attenuator is used, be sure to include its attenuation in the measurement of the channel power. Use the **Ext Atten** key.

The channel power measurement, very often along with the adjacent channel power ratio measurement and/or spectrum measurement, can reveal degraded or defective parts in the transmitter section of the UUT. The following examples are those areas to be checked further.

- Some faults in the DC power supply control of the transmitter power amplifier, RF power controller of the pre-power amplifier stage, and/or I/Q control of the baseband stage.
- Some degradation in the gain and output power level of the amplifier due to the degraded gain control and/or increased distortion.
- Some degradation of the amplifier linearity and other performance characteristics.

Making the Modulation Accuracy (Rho) Measurement

Purpose

This procedure measures the performance of the transmitter's modulation circuitry.

Measurement Method

The E4406A can perform base station and mobile measurements. In both cases the transmitter's modulated signal is compared to an ideal reference waveform. Rho values are in the range of 0 to 1. A value of 1 indicates perfect correlation to the reference (high modulation quality).

The cdmaOne base station standards require that transmitters have a Rho performance of 0.912 or greater.

When performing mobile testing with the Rho measurement, the phone must be placed in a test mode to modulate only the known short code sequences in the reverse link. The measurement will not work with a live phone call on which data is being modulated.

With the Rho measurement, the following data is provided:

- Rho - modulation quality
- Time Offset - how well your transmitter's signal is time-aligned to system time
- Frequency Error - the frequency difference between your transmitter's actual center frequency and the frequency (or channel) that you entered
- Carrier Feedthrough - measures the performance of the I/Q modulator of your transmitter
- EVM - rms Error Vector Magnitude
- Mag Error - rms Magnitude Error
- Phase Error - rms Phase Error

Making the Measurement

NOTE

The factory default settings provide a cdmaOne compliant measurement. For special requirements, you may need to change some of the settings. Press **Meas Setup, More (1 of 2), Restore Meas Defaults** at any time to return all parameters for the current measurement to their default settings.

Select the desired center frequency and PN offset as described under [“Changing the Frequency Channel” on page 19](#).

Press **Measure, Mod Accuracy (Rho)** to immediately make Modulation Accuracy the active measurement.

To change any of the measurement parameters from the factory default values, refer to [“Changing the Measurement Setup” on page 54](#).

Results

Figure 3-2 Modulation Accuracy Result - Quad View (chip dots off)

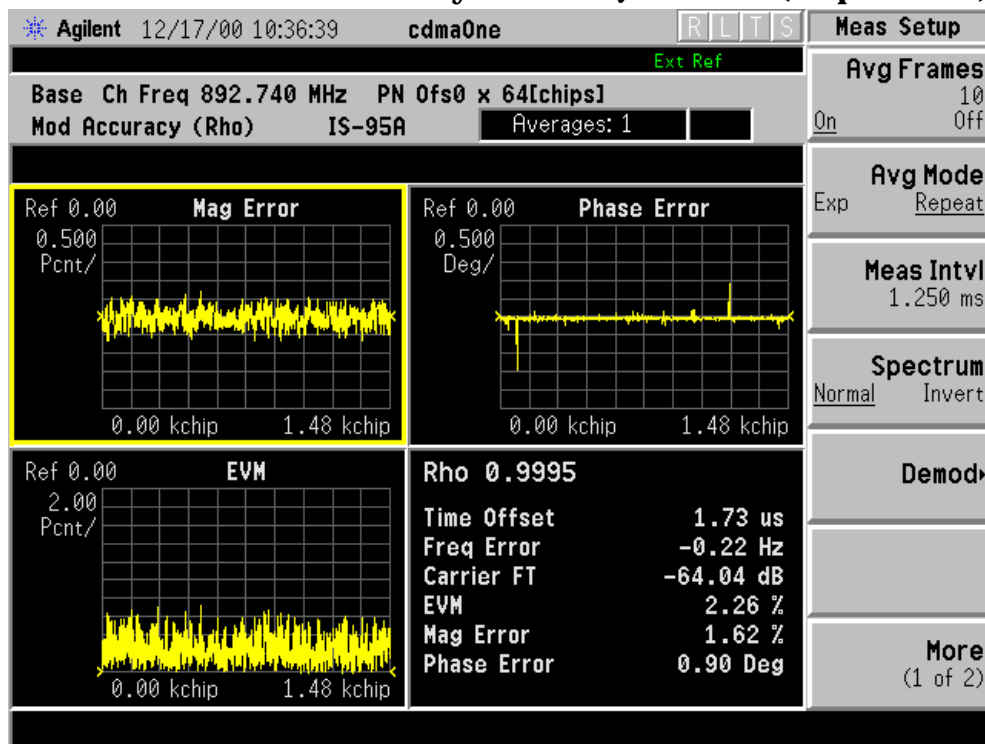

Figure 3-3 Modulation Accuracy Result - Phase Error View

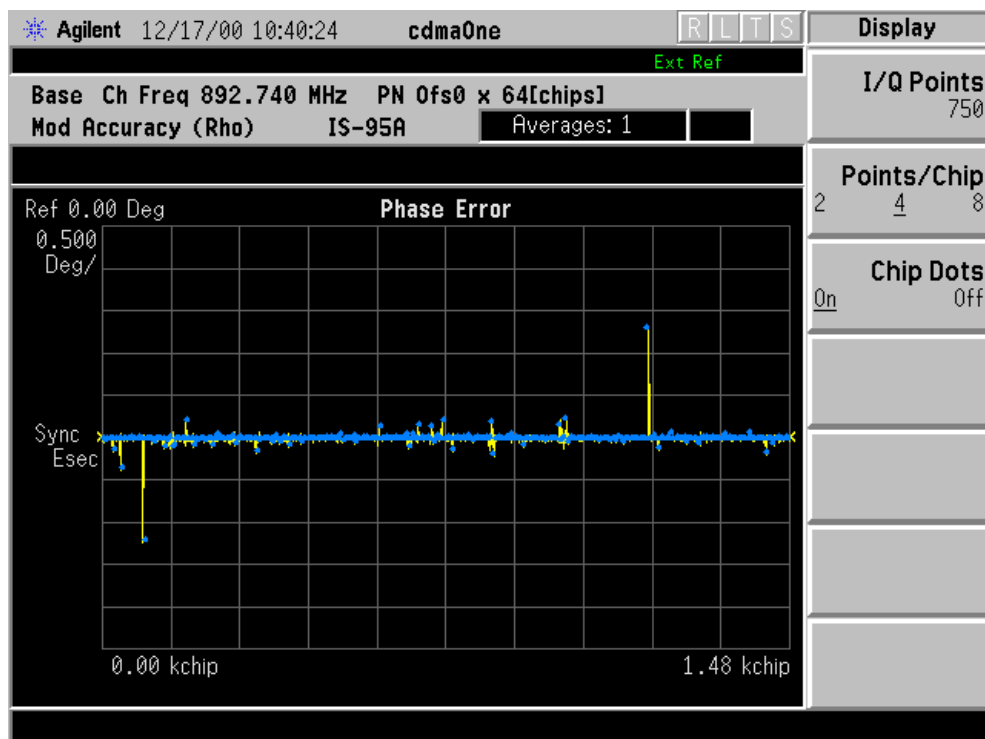

Figure 3-4 Modulation Accuracy Result - EVM View

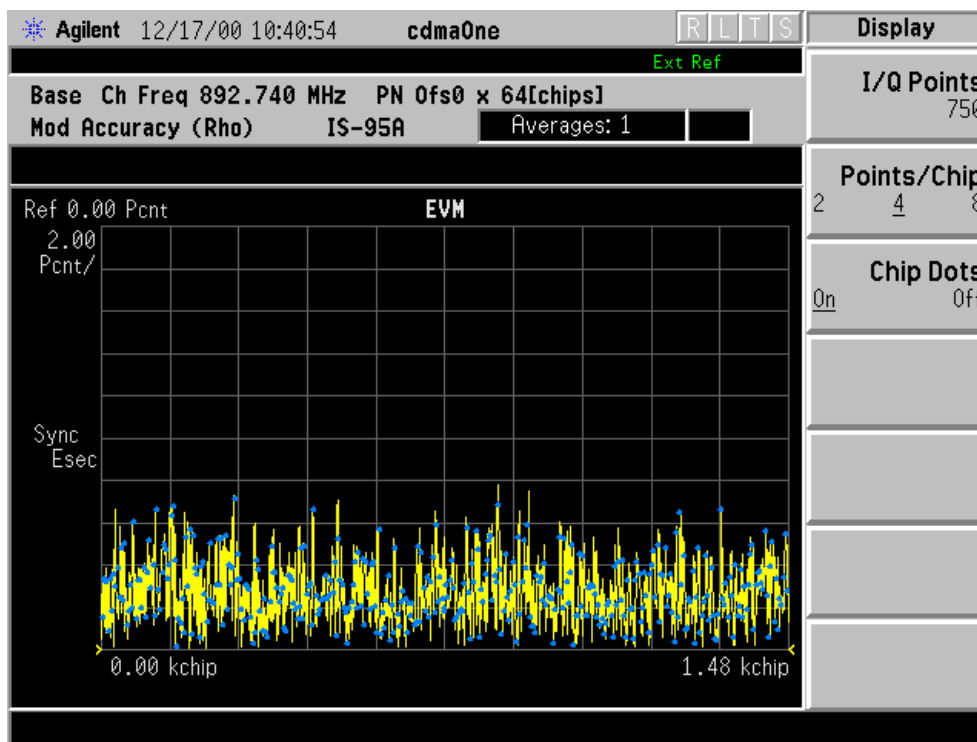
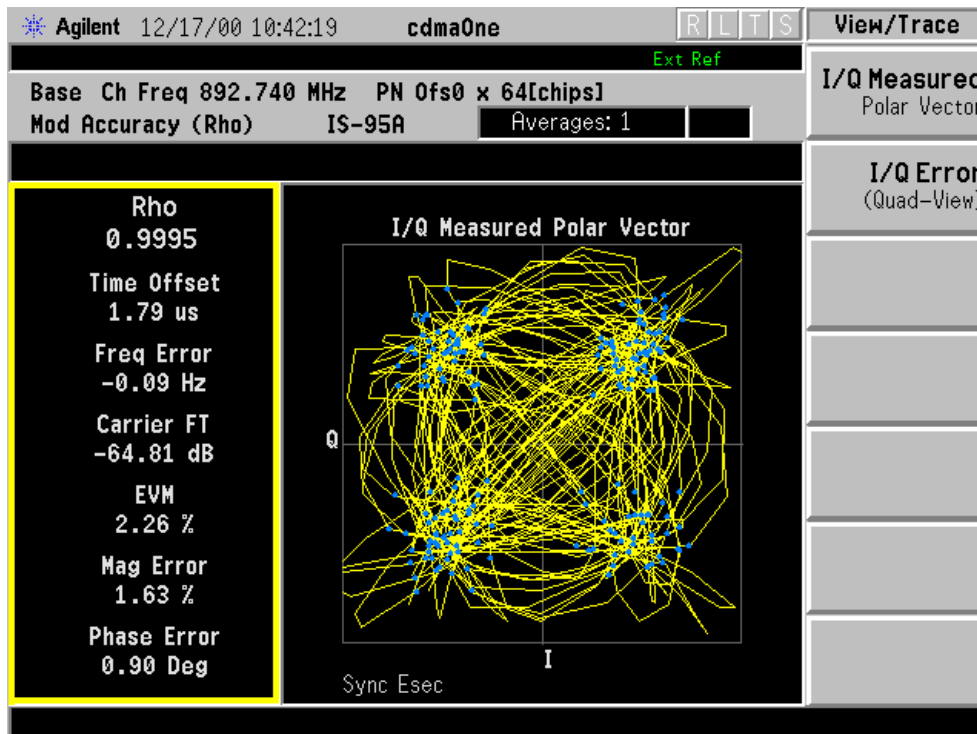

Figure 3-5 Modulation Accuracy Result - Polar Vector View



Changing the Measurement Setup

Table 3-2 Modulation Accuracy (Rho) Measurement Defaults

Measurement Parameter	Factory Default Condition
Avg Frames	10 On
Avg Mode	Repeat
Meas Intvl	1.25 ms
Spectrum	Normal
Demod	
Sync Type	Even Sec (Ext Rear)
PN Offset	0×64 [chips]
RF Carrier	Single

Make sure the **Mod Accuracy (Rho)** measurement is selected under the **Measure** menu. Press the **Meas Setup** key to access a menu which allows you to modify the averaging, measurement interval, spectrum, and demodulation (as described in the [“Measurement Setup” on page 42](#)).

- **Meas Interval** - Sets the time interval over which the measurement is made.
- **Spectrum** - This key, when set to **Invert**, conjugates the spectrum, which equivalently negates the quadrature component in demodulation. The correct setting (**Normal** or **Invert**) depends on whether the signal being given to the transmitter tester has a high or low side mix.

Changing the View

The **View/Trace** key will allow you to select the desired view of the measurement from the following:

- **I/Q Error (Quad-View)** - See [Figure 3-2 on page 52](#). Provides a combination view including:

Window 1: Magnitude Error vs. chip

Window 2: Phase Error vs. chip

Window 3: EVM vs. chip

Window 4: Numeric results

Any of these windows can be selected (using the **Next Window** key) and made full size (using the **Zoom** key).

- **I/Q Measured**- Provides a combination view of numeric results and a polar graph.

Window 1: Numeric Results

Window 2: Polar Graph

Four different graphic views can be chosen:

- Complimentary Vector
- Complimentary Constellation
- Polar Vector
- Polar Constellation

Changing the Display

The **Display** key will allow you to access the following keys:

- **I/Q Points** - Default is 750.
- **Points/Chip** - Default is 4. This is the number of sample points displayed per chip.
- **Chip Dots** - Default is On. Set to Off if you do not want the chip dots to be superimposed on the Result traces.

Making the Code Domain Measurement (Base Station Only)

Purpose

The code domain measurement displays the power for each of the 64 Walsh channels, relative to the total power inside a 1.23 MHz bandwidth centered at the Center Frequency. Each Walsh channel level is displayed as an individual vertical bar. Because this is a relative measurement, the unit of measure is dB (not dBm or watts). This allows a comparison of signal levels between the Pilot, Sync, Paging, and Traffic channels.

Measurement Method

This procedure measures the power, timing, and phase of the 64 Walsh channels in a single RF channel. The measurement method can be selected to either measure just code domain power, or to measure code domain power, timing, and phase. The measurement runs faster when measuring only code domain power.

Code Domain Phase

Code Domain Phase displays the phase error for each of the 64 Walsh channels relative to the Pilot channel. Displays above the zero reference in the center of the screen indicate that the Walsh channel leads the Pilot channel; displays below the zero reference in the center of the screen indicate that the Walsh channel lags the Pilot channel. Move the marker to read the phase for each individual channel.

Code Domain Timing

Code Domain Timing displays the time offset for each of the 64 Walsh channels relative to the Pilot channel which is Walsh code zero. Displays above the reference indicate that the Walsh channel leads the Pilot channel; displays below the zero reference indicate that the Walsh channel lags the Pilot channel. Move the marker to read the Timing for each individual channel

Time Offset

Time Offset indicates how well your transmitter's signal is time-aligned to system time. The displayed value takes into account the PN Sequence Offset Index of your transmitter that is entered using the **PN Offset** key

Frequency Error

Frequency Error is the frequency difference between your transmitter's actual center frequency and the frequency (or channel) that you entered.

Carrier Feedthrough

Carrier Feedthrough is used to measure the performance of the I/Q modulator of your transmitter. Extremely low values indicate a very good I/Q modulator. Higher values indicate potential problems with the I/Q modulator. If Carrier Feedthrough measures higher than approximately -20 dBc, there may be problems with the base station.

Avg AT	Average Active Traffic Power (of all active Walsh channels). A Walsh channel is considered active if its power is above the value set by the Active Set Th key.
Max IT	Maximum Inactive Traffic power (of all inactive Walsh channels).
Avg IT	Average Inactive Traffic power (of any inactive Walsh channel).

Making the Measurement

NOTE

The factory default settings provide a cdmaOne compliant measurement. For special requirements, you may need to change some of the settings. Press **Meas Setup, More (1 of 2), Restore Meas Defaults** at any time to return all parameters for the current measurement to their default settings.

Select the desired center frequency and PN offset as described under [“Changing the Frequency Channel” on page 19](#).

Press **Measure, Code Domain** to immediately make Code Domain Power the active measurement.

To change any of the measurement parameters from the factory default values, refer to [“Changing the Measurement Setup” on page 59](#).

Results

Figure 3-6 Code Domain Measurement - Power Graph and Metrics View

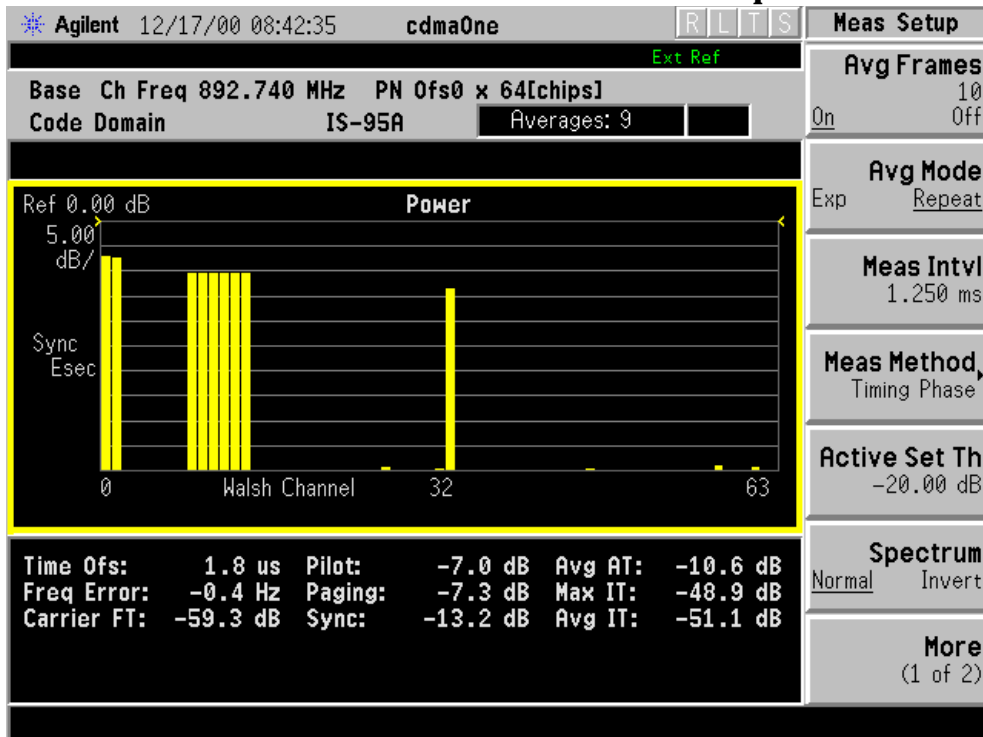

Figure 3-7 Code Domain Measurement - Power Graph and Markers View

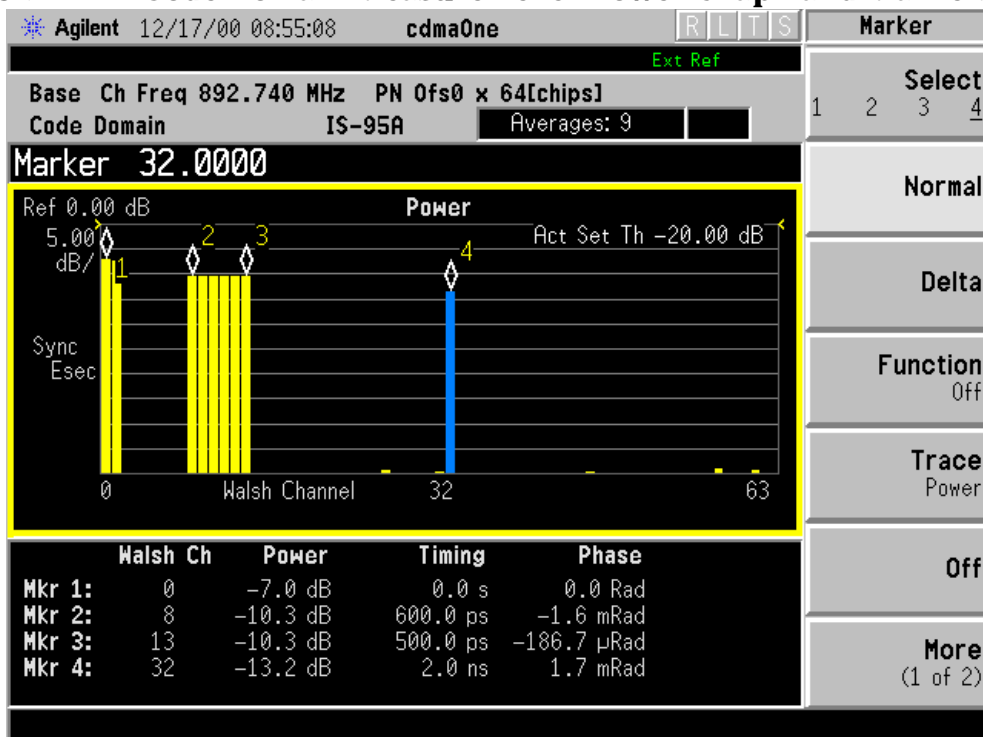
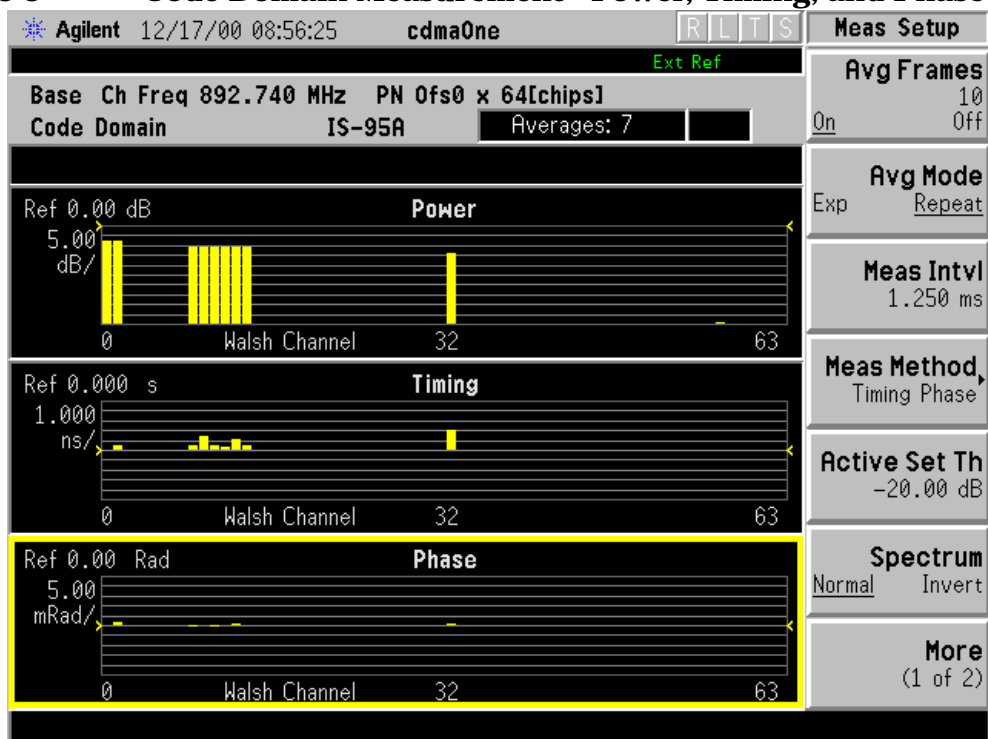

Figure 3-8 Code Domain Measurement - Power, Timing, and Phase View



Changing the Measurement Setup

Table 3-3 Code Domain Measurement Defaults

Measurement Parameter	Factory Default Condition
Avg Frames	10 On
Avg Mode	Repeat
Meas Interval	1.250 ms
Meas Method	Power
Active Set Th	-20.00 dB
Spectrum	Normal
Demod	
Sync Type	Even Sec (Ext Rear)
PN Offset	0 × 64[chips]
RF Carrier	Single

Make sure the **Code Domain** measurement is selected under the **Measure** menu. Press the **Meas Setup** key to access a menu which allows you to modify the measurement parameters.

Meas Invl	Sets the time interval over which the measurement is made.
Meas Method	— Power - Only measures code domain power (fastest). — Timing Phase - Measures code domain power, timing, and phase.
Active Set Th	Active Set Threshold sets the relative power level used to separate active from inactive traffic channels.

Changing the View

The **View/Trace** key will allow you to select the desired view of the measurement from the following. Each of these views contains multiple windows that can be selected (using the **Next Window** key) and made full size (using the **Zoom** key).

Power Graph & Metrics Provides a combination view including:

- Window 1: Code Domain Power
- Window 2: Numeric Summary

Power Graph & Markers Provides a combination view including:

- Window 1: Code Domain Power
- Window 2: Numeric results for any 4 code channels (user set by using Markers)

Power Timing & Phase Provides a combination view including:

- Window 1: Code Domain Power
- Window 2: Code Domain Timing
- Window 3: Code Domain Phase

Changing the Display

The **Display** key will allow you to access the **Points/Chip** - Default is 2

Making the Spur Close Measurement

Purpose

This procedure measures the spurious emissions in the transmit band relative to channel power in the selected channel. The unit under test is typically set for maximum output power. The measurement can be used when the unit under test is set for output power less than maximum, however the limits used might not be correct.

Measurement Method

The transmit band spectrum is measured in several frequency segments using resolution bandwidths as specified by the standard. The channel power (integrated power in a 1.23 MHz bandwidth) is measured first, and then used as a reference for the measurement limit lines. The spectrum, centered around the carrier as well as above and below the carrier, is then measured. For each spectrum segment, the measurement looks for the spectrum peak closest to the limit and reports it as the `Worst Spur`. The amplitude difference from peak to the limit line (Δ from Limit), the frequency difference from the peak to the center of the channel (Offset Freq), and the amplitude difference from the peak to the channel power (Δ from Carrier) are displayed. If the peak goes above the limit line, the display will indicate `FAIL`. If `Marker` is on, the active marker is placed at the worst spur of the displayed segment.

Table 3-4 Spurious Emission Limits When Transmitting

Band	Device Type	Frequency Offset	Limit
IS-95-A	Base	> 750 kHz	-45 dBc/30 kHz
		> 1.98 MHz	-60 dBc/30 kHz
		outside channel's band but inside Tx band	-13 dBm/30 kHz or -60 dBc/30 kHz, whichever is the smaller power
		outside Tx band	-13 dBm/100 kHz
	Mobile	> 885 kHz	-42 dBc/30 kHz
		> 1.98 MHz	-54 dBc/30 kHz
		outside channel's band but inside Tx band	-54 dBm/30 kHz
		outside Tx band	-13 dBm/100 kHz
J-STD-008	Base	> 885 kHz	-45 dBc/30 kHz
		≤ 1 MHz outside & adjacent to the channel's band	-13 dBm/12.5 kHz or -80 dBc/12.5 kHz, whichever is the greater power
		> 1 MHz outside channel's band but inside Tx band	-13 dBm/1 MHz or -80 dBc/1 MHz, whichever is the greater power
		outside Tx band	-13 dBm/1 MHz
	Mobile	> 1.265 MHz	-42 dBc/30 kHz
		≤ 1 MHz outside & adjacent to the channel's band	-13 dBm/12.5 kHz
		> 1 MHz outside channel's band but inside Tx band	-13 dBm/1 MHz
		outside Tx band	-13 dBm/1 MHz

Making the Measurement

NOTE

The factory default settings provide a cdmaOne compliant measurement. For special requirements, you may need to change some of the settings. Press **Meas Setup, More (1 of 2), Restore Meas Defaults** at any time to return all parameters for the current measurement to their default settings.

Select the desired center frequency as described under [“Changing the Frequency Channel” on page 19](#).

Press **Measure, Spur Close** to immediately make Spur Close the active measurement.

To change any of the measurement parameters from the factory default values, refer to [“Changing the Measurement Setup” on page 66](#).

Results

Figure 3-9 Spur Close Measurement, IS-95A - Center Segment View

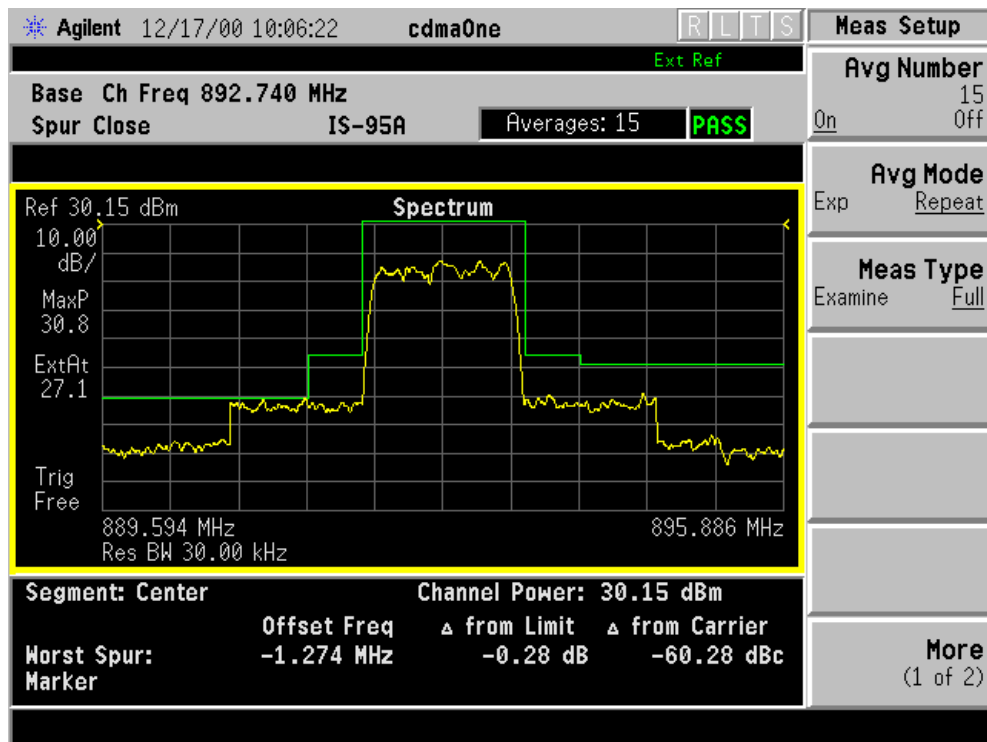

Figure 3-10 Spur Close Measurement, IS-95A - Lower Segment View

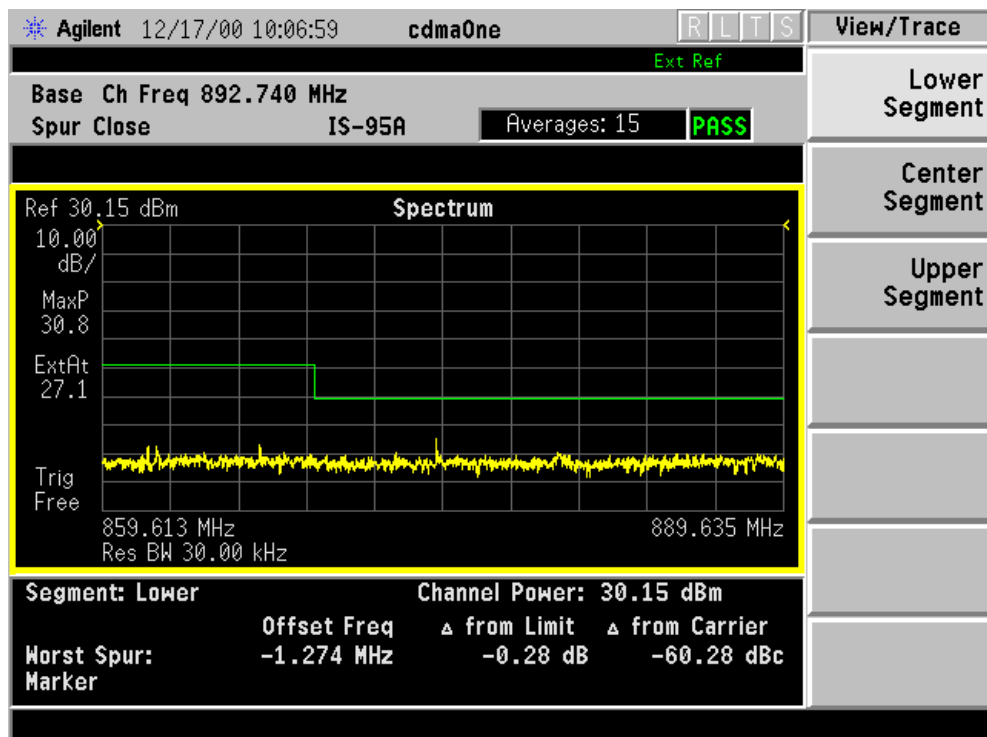
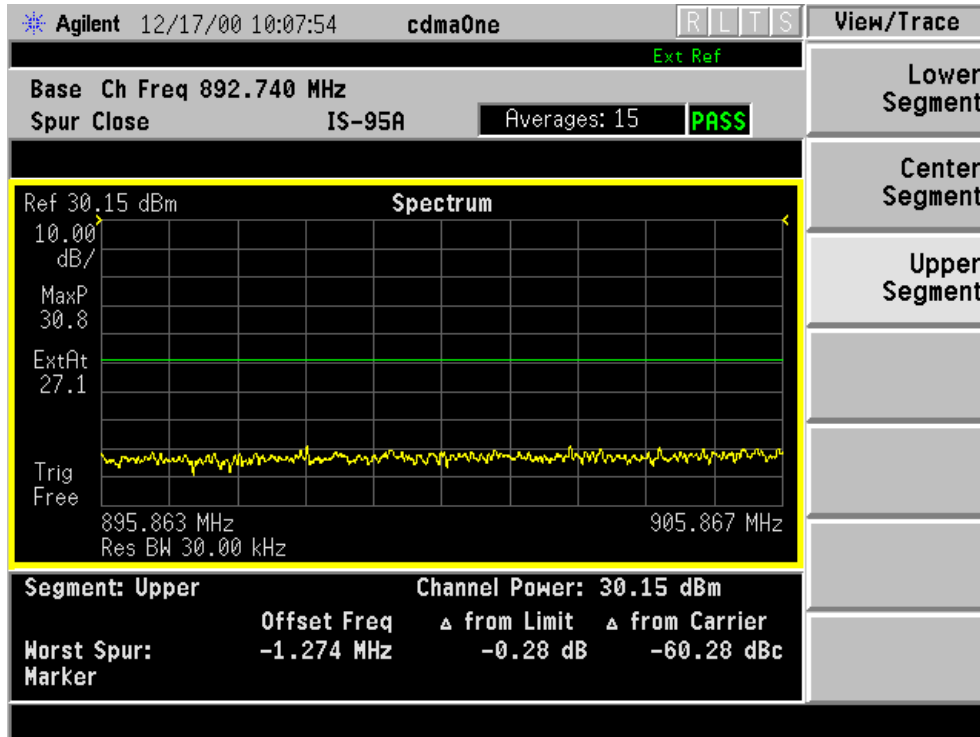

Figure 3-11 Spur Close Measurement, IS-95A - Upper Segment View



Changing the Measurement Setup

Table 3-5 Spur Close Measurement Defaults

Measurement Parameter	Factory Default Condition
Avg Number	15 On
Avg Mode	Repeat
Meas Type	Full

Make sure the **Spur Close** measurement is selected under the **Measure** menu. Press the **Meas Setup** key to access a menu which allows you to modify the measurement parameters.

Changing the View

The **View/Trace** key will allow you to select the desired view of the measurement from the following. Each of these choices selects a different part of the frequency spectrum for viewing. The **Center Segment** shows the spectrum centered on the carrier channel frequency.

When **Band** is set to IS-95:

- **Lower Segment**
- **Center Segment**
- **Upper Segment**

When **Band** is set to J-STD-008:

- **Lower Segment**
- **Lower 1 MHz Adj Segment**
- **Center Segment**
- **Upper 1 MHz Adj Segment**
- **Upper Segment**

Making the Spectrum (Frequency Domain) Measurement

Purpose

The spectrum measurement provides spectrum analysis capability for the instrument. The control of the measurement was designed to be familiar to those who are accustomed to using swept spectrum analyzers.

This measurement is FFT (Fast Fourier Transform) based. The FFT-specific parameters are located in the **Advanced** menu. Also available under basic mode spectrum measurements is an I/Q window, which shows the I and Q signals in parameters of voltage and time. The advantage of having an I/Q view available while in the spectrum measurement is that it allows you to view complex components of the same signal without changing settings or measurements.

Measurement Method

The transmitter tester uses digital signal processing to sample the input signal and convert it to the frequency domain. With the instrument tuned to a fixed center frequency, samples are digitized at a high rate, converted to I and Q components with DSP hardware, and then converted to the frequency domain with FFT software.

Making the Measurement

NOTE

The factory default parameters provide a good starting point. You will likely want to change some of the settings. Press **Meas Setup, More (1 of 2), Restore Meas Defaults** at any time to return all parameters for the current measurement to their default settings.

Press **Measure, Spectrum (Freq Domain)** to immediately make Spectrum (Frequency Domain) the active measurement.

To change any of the measurement parameters from the factory default values, refer to the “Changing the Measurement Setup” section for this measurement.

Results

A display with both a spectrum window and an I/Q Waveform window will appear when you activate a spectrum measurement. Use the **Next Window** key to select a window, and the **Zoom** key to enlarge a window.

Figure 3-12 **Spectrum Measurement Result- Spectrum Window**

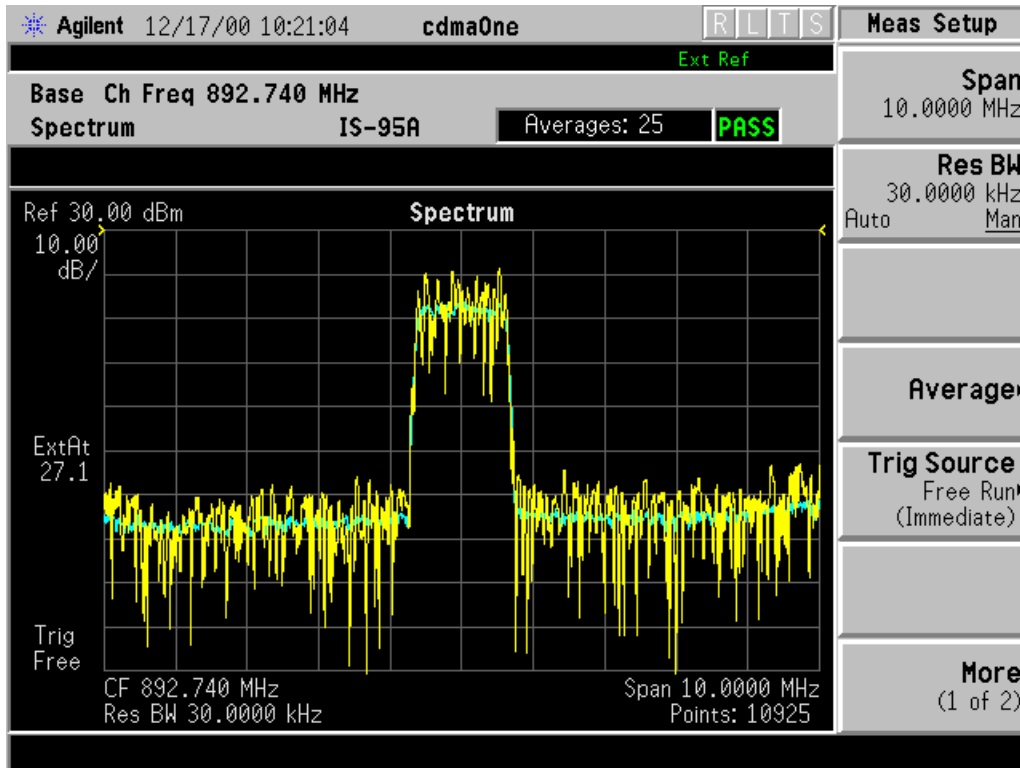

Changing the Measurement Setup

Table 1 Spectrum (Frequency Domain) Measurement Defaults

Measurement Parameter	Factory Default Condition
Res BW	20.0000 kHz (Auto)
Averaging:	
Avg Number	25 On
Avg Mode	Exp
Avg Type	Log-Pwr Avg (Video)
Trigger Source	Free Run (Immediate)
Measurement Time (Service mode only)	1.0 ms (Auto)
Spectrum Window:	
Span	1.00000 MHz
Scale/Div - Amplitude Y Scale	10.00 dB
I/Q Waveform Window:	
Capture Time	188.00 μ s
Scale/Div - Amplitude Y Scale	60 mV
Advanced	
Pre-ADC BPF	On
Pre-FFT Filter	Flat
Pre-FFT BW	1.55000 MHz (Auto)
FFT Window	Flat Top (High AmptdAcc)
FFT Size:	
Length Control	Auto
Min Points/RBW	1.300000
Window Length	706
FFT Length	4096
ADC Range	Auto Peak
Data Packing	Auto
ADC Dither	Auto
Decimation	0 (Auto)
IF Flatness	On

NOTE

Parameters under the **Advanced** key seldom need to be changed. Any changes from the default advanced values may result in invalid measurement data.

Make sure the **Spectrum (Freq Domain)** measurement is selected under the **Measure** menu. Press the **Meas Setup** key to access a menu which allows you to modify the averaging, and trigger source for this measurement (as described in the “Measurement Setup” section). In addition, the following parameters can be modified:

- **Span** - This key allows you to modify the frequency span. Changing the span causes the bandwidth to change automatically, and will affect data acquisition time.
- **Res BW** - This feature sets the resolution bandwidth for the FFT, and allows manual or automatic settings. A narrower bandwidth will result in a longer data acquisition time. In Auto mode the resolution bandwidth is set to Span/50 (2% of the span).
- **Advanced** - The following FFT advanced features should be used only if you are familiar with their operation. Changes from the default values may result in invalid data.

Pre-ADC BPF - This key allows you to toggle the pre-ADC bandpass filter to On or Off states. The pre-ADC bandpass filter is useful for rejecting nearby signals, so that sensitivity within the span range can be improved by increasing the ADC range gain.

Pre-FFT Fltr - Allows you to toggle between **Flat** (flat top) and **Gaussian**. The pre-FFT filter defaults to a flat top filter which has better amplitude accuracy. The Gaussian filter has better pulse response.

Pre-FFT BW - The Pre-FFT bandwidth allows you to select between a manual or an automatic setting. The pre FFT-bandwidth filter can be set between 1 Hz and 10 MHz. In Auto mode this bandwidth is nominally 50% wider than the span. This bandwidth determines the ADC sampling rate.

FFT Window - Allows you to access the following selection menu. Unless you are familiar with FFT windows, use the flat top filter (the default filter).

- **Flat Top** - Selects a filter for best amplitude accuracy, by reducing scalloping error.
- **Uniform** - You can select to have no window active by using the uniform setting.
- **Hanning**
- **Hamming**
- **Gaussian** - Selects a gaussian filter with an alpha of 3.5.
- **Blackman**
- **Blackman Harris**
- **K-B 70dB / 90dB/ 110dB (Kaiser-Bessel)** - Allows selection of Kaiser-Bessel filters with sidelobes of -70, -90, or -110 dBc.

FFT Size - This menu contains the following features:

- **Length Ctrl** - This feature allows you to set the FFT and window lengths either automatically or manually.
- **Min Pts in RBW** - This feature allows you to set the minimum number of data points that will be used inside the resolution bandwidth. This adjustment is only available if the Length Ctrl key is set to Auto.
- **Window Length** - This feature allows you to enter the FFT window length ranging from 8 to 1048576. This length represents the actual quantity of I/Q samples that are captured for processing by the FFT. This value can only be entered if length control is set to Manual.
- **FFT Length** - This feature allows you to enter the FFT length in the number of captured samples, ranging from 4096 to 1048576. The FFT length setting is automatically limited so that it is equal or greater than the FFT window length setting. Any amount greater than the window length is implemented by zero-padding. This value can be entered only if length control is set to Man (manual).

ADC Range - Allows you to access the following selection menu to define one of the following ADC ranging functions:

- **Auto** - Select this to set the ADC range automatically. For most FFT spectrum measurements, the auto feature should not be selected. An exception is when measuring a signal which is “bursty”, in which case auto can maximize the time domain dynamic range, if FFT results are less important to you than time domain results.
- **Auto Peak** - Select this to set the ADC range automatically to the peak signal level. Auto peak is a compromise that works well for both CW and burst signals.

- **AutoPeakLock** - Select this to hold the ADC range automatically at the peak signal level. Auto peak lock is more stable than auto peak for CW signals, but should not be used for “bursty” signals.
- **Manual** - Allows you to access the selection menu: **-6 dB, 0 dB, +6 dB, +12 dB, +18 dB, +24 dB**, to set the ADC range level. Also note that manual ranging is best for CW signals.

Data Packing - Allows you to access the following selection menu to define one of the following data packing methods:

- **Auto** - Data is automatically packed. This is the default setting and most recommended.
- **Short (16 bit)** - Data is packed by every 16 bits.
- **Medium (24 bit)** - Data is packed by every 24 bits.
- **Long (32 bit)** - Data is packed by every 32 bits.

ADC Dither - Allows you to toggle the ADC dither function between **Auto, On, and Off**. When set to auto (the default), ADC dither will be activated when a narrow bandwidth is being measured, and deactivated when a wide bandwidth is being measured. “ADC dither” refers to the introduction of noise to the digitized steps of the analog-to-digital converter; the result is an improvement in amplitude accuracy. Use of the ADC dither, however, reduces dynamic range by approximately 3 dB.

Decimation - Allows you to toggle the decimation function between **Auto** and **Man**, and to set the decimation value. **Auto** is the preferred setting, and the only setting that guarantees alias-free FFT spectrum measurements. If you are familiar with the decimation feature, you can change the decimation value by setting to **Man**, but be aware that aliasing can result in higher values.

IF Flatness - Allows you to toggle between **On** and **Off**. When toggled to **On** (the default), the IF flatness feature causes background amplitude corrections to be performed on the FFT spectrum. The **Off** setting is used for adjustment and troubleshooting the transmitter tester.

Changing the View

View/Trace menu keys are used to activate a view of a measurement with preset X and Y scale parameters, called a “window”. Using the X and Y Scale keys you can then modify these parameter settings. You can also activate specific traces, using the **Trace Display** menu key.

Windows Available for Spectrum Measurements

The spectrum and the I/Q windows can be viewed at the same time, or individually. You can use the **Next Window** and **Zoom** keys to move between these different views.

Spectrum window Select this window if you want to view frequency and power. Changes to frequency span or power will sometimes affect data acquisition.

I/Q Waveform window. Select this window to view the I and Q signal characteristics of the current measurement in parameters of voltage and time.

NOTE

For the widest spans the I/Q window becomes just “ADC time domain samples”, because the I/Q down-conversion is no longer in effect.

Using the Markers

The **Marker** front-panel key accesses the menu to configure the markers. If you want to use the marker function in the I/Q window, press **View/Trace, I/Q Waveform, Marker, Trace, IQ Waveform**.

- **Select 1 2 3 4** - Allows you to activate up to four markers with the corresponding numbers, respectively. The selected number is underlined and its function is defined by pressing the **Function** key. The default is 1.
- **Normal** - Allows you to activate the selected marker to read the frequency and amplitude of the marker position on the spectrum trace, for example, which is controlled by the **RPG** knob.
- **Delta** - Allows you to read the differences in frequencies and amplitudes between the selected marker and the next.
- **Function Off** - Allows you to define the selected marker function to be **Band Power**, **Noise**, or **Off**. The default is **Off**. If set to **Band Power**, you need to select **Delta**.
- **Trace Spectrum** - Allows you to place the selected marker on the **Spectrum**, **Spectrum Avg**, or **I/Q Waveform** trace. The default is **Spectrum**.
- **Off** - Allows you to turn off the selected marker.

- **Shape Diamond** - Allows you to access the menu to define the selected marker shape to be a **Diamond**, **Line**, **Square**, or **Cross**. The default is a **Diamond**.
- **Marker All Off** - Allows you to turn off all of the markers.

The front panel **Search** key performs a peak search when pressed. A marker will automatically be activated at the highest peak.

Band Power

A band power measurement using the markers calculates the average power between two adjustable markers. To make a band power measurement:

Press the **Marker** key.

Press **Trace**, **Spectrum** to activate a marker on the instantaneous spectrum signal. Press the **Spectrum Avg** key to activate a marker on the average spectrum trace.

Press **Function**, **Band Power**.

Two marker lines are activated at the extreme left side of the horizontal scale. Press **Normal** and move marker 1 to the desired place by rotating the **RPG** knob.

Press **Delta** to bring marker 2 to the same place as marker 1.

Move marker 1 to the other desired position by rotating the **RPG** knob. Band power measures the average power between the two markers. When the band power markers are active, the results are shown in the results window as Mean Pwr (Between Mks). When the band power function is off the results window reads Mean Pwr (Entire Trace).

Troubleshooting Hints

Changes made by the user to advanced spectrum settings, particularly to ADC range settings, can inadvertently result in spectrum measurements that are invalid and cause error messages to appear. Care needs to be taken when using advanced features.

Making the Waveform (Time Domain) Measurement

Purpose

The waveform measurement is a generic measurement for viewing waveforms in the time domain. This measurement is how the instrument performs the zero span functionality found in traditional spectrum analyzers. Also available under basic mode waveform measurements is an I/Q window, which shows the I and Q signal in parameters of voltage and time. The advantage of having an I/Q view available while in the waveform measurement is that it allows you to view complex components of the same signal without changing settings or measurements.

The waveform measurement can be used to perform general purpose power measurements to a high degree of accuracy.

Measurement Method

The transmitter tester makes repeated power measurements at a set frequency, similar to the way a swept-tuned spectrum analyzer makes zero span measurements. The input analog signal is converted to a digital signal, which then is processed into a representation of a waveform measurement. The transmitter tester relies on a high rates of sampling to create an accurate representation of a time domain signal.

Making the Measurement

NOTE

The factory default parameters provide a good starting point. You will likely want to change some of the settings. Press **Meas Setup, More (1 of 2), Restore Meas Defaults** at any time to return all parameters for the current measurement to their default settings.

Press **Measure, Waveform (Time Domain)** to immediately make Waveform (Time Domain) the active measurement.

To change any of the measurement parameters from the factory default values, refer to the “Changing the Measurement Setup” section for this measurement.

Results

Figure 3-13 Waveform Measurement Results- RF Envelope Window

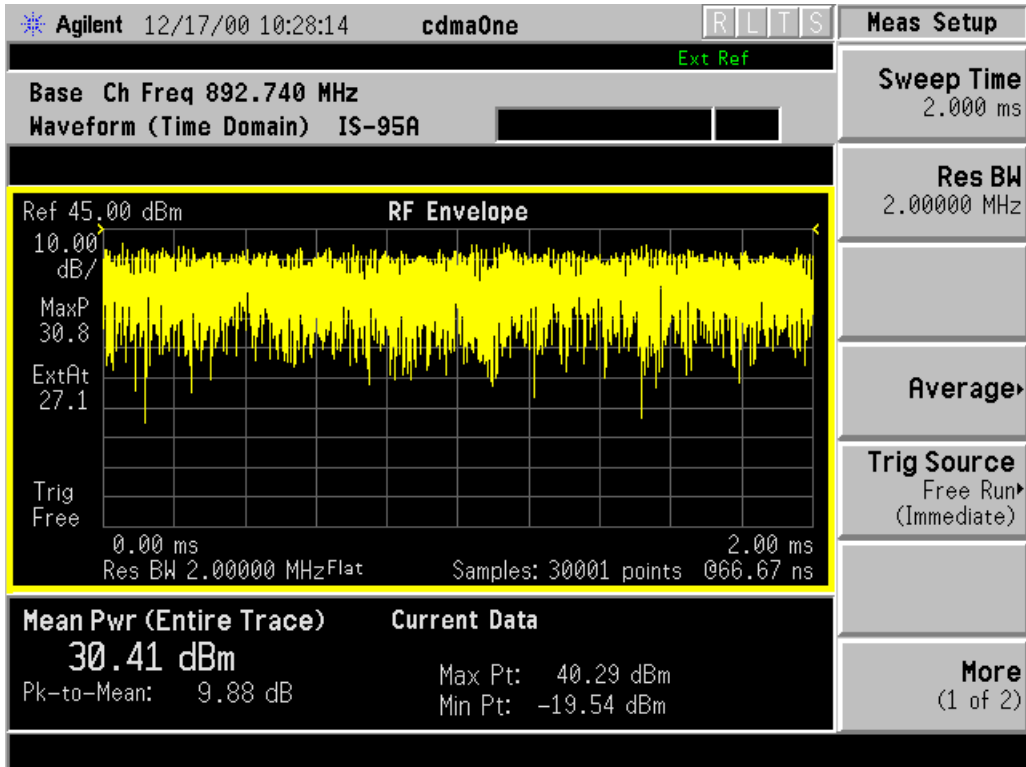

Changing the Measurement Setup

Table 2 Waveform (Time Domain) Measurement Defaults

Measurement Parameter	Factory Default Condition
View/Trace	RF Envelope
Sweep Time	2.000 ms
Res BW	2.00000 MHz
Averaging:	
Avg Number	10 Off
Avg Mode	Exp
Avg Type	Pwr Avg (RMS)
Trigger Source	Free Run (Immediate)
RF Envelope Window:	
Amplitude Y Scale	
Scale/Div	10.00 dB
Reference	0.00 dBm (Top)
I/Q Waveform Window:	
Amplitude Y Scale	
Scale/Div	100.0 mv
Reference	0.00 V (Ctr)
Advanced	
Pre-ADC BPF	Off
RBW Filter	Gaussian
ADC Range	Auto
Data Packing	Auto
ADC Dither	Off
Decimation	Off

NOTE Parameters that are under the **Advanced** key seldom need to be changed. Any changes from the default values may result in invalid measurement data.

Make sure the **Waveform (Time Domain)** measurement is selected under the **Measure** menu. Press the **Meas Setup** key to access a menu which allows you to modify the averaging, and trigger source for this measurement (as described in the “Measurement Setup” section). In addition, the following parameters can be modified:

- **Sweep Time** - This key allows you to select the measurement acquisition time. It is used to specify the length of the time capture record. Values between 10 μ s and 50 s can be entered, depending upon the resolution bandwidth setting.
- **Res BW** - This key sets the measurement bandwidth. A larger bandwidth results in a larger number of acquisition points and reduces the maximum allowed for sweep time. You can enter values between 10 Hz. and 7.5 MHz.
- **Advanced menu key**. This key accesses the features listed below.

Pre-ADC BPF - This key allows you to toggle the pre-ADC bandpass filter to On or Off states. The pre-ADC bandpass filter is useful for rejecting nearby signals, so that sensitivity within the span range can be improved by increasing the ADC range gain

RBW Filter - This key toggles to select a flat top or a Gaussian resolution bandwidth filter. A Gaussian filter provides more even time domain response, particularly for bursts. A flat top filter provides a flatter bandwidth but is less accurate for pulse responses. A flat top filter also requires less memory and allows longer data acquisition times. For most waveform applications, the Gaussian filter is recommended, and it is the default filter for waveform measurements.

ADC Range -.Allows you to access the following selection menu to define one of the following ADC ranging functions:

- **Auto** - This key causes the instrument to automatically adjust the signal range for optimal measurement results.
- **AutoPeak** - This key causes the instrument to continuously seek the highest peak signal.
- **AutoPeakLock** - This key causes the instrument to adjust the range for the highest peak signal it identifies, and retains the range settings determined by that peak signal, even when the peak signal is no longer present.
- **Manual** - Allows you to access the selection menu: **-6 dB, 0 dB, +6 dB, +12 dB, +18 dB, +24 dB**, to set the ADC range level. Also note that manual ranging is best for CW signals.

Data Packing - Allows you to access the following selection menu to define one of the following data packing methods:

- **Auto** - Data is automatically packed. This is the default setting and most recommended.
- **Short (16 bit)** - Data is packed by every 16 bits.
- **Medium (24 bit)** - Data is packed by every 24 bits.
- **Long (32 bit)** - Data is packed by every 32 bits.

ADC Dither - Allows you to toggle the ADC dither function between **On** and **Off**. Activation of the ADC dither results in better amplitude linearity and resolution in low level signals. However, it also results in reduced dynamic range. ADC dither is set to **Off** by default.

Decimation - Allows you to toggle the decimation function between **On** and **Off** and to set the decimation value. Decimation allows longer acquisition times for a given bandwidth by eliminating data points. Long time captures can be limited by the transmitter tester data acquisition memory. Decimation numbers 1 to 4 describe the factor by which the number of points are reduced. A decimation figure of 1, which results in no data point reduction, is the default.

Changing the View

The **View/Trace** menu keys are used to activate a view of a measurement with preset X and Y scale parameters; this view is called a “window.” Using the X and Y scale keys, you can then modify these parameters. You can also activate traces, using the **Traces Display** menu key.

Windows Available for Waveform Measurements

RF Envelope window. Select this window if you want to view power (in dBm) vs. time. Remember that data acquisition will be affected when you change the sweep time.

I/Q Waveform window. Select this window to view the I and Q signal characteristics of the current measurement in parameters of voltage and time.

Using the Markers

The **Marker** front-panel key accesses the menu to configure the markers. If you want to use the marker function in the I/Q window, press **View/Trace, I/Q Waveform, Marker, Trace, IQ Waveform.**

- **Select 1 2 3 4** - Allows you to activate up to four markers with the corresponding numbers, respectively. The selected number is underlined and its function is defined by pressing the **Function** key. The default is 1.
- **Normal** - Allows you to activate the selected marker to read the frequency and amplitude of the marker position on the spectrum trace, for example, which is controlled by the **RPG** knob.
- **Delta** - Allows you to read the differences in frequencies and amplitudes between the selected marker and the next.
- **Function Off** - Allows you to define the selected marker function to be **Band Power, Noise, or Off**. The default is **Off**. If set to **Band Power**, you need to select **Delta**.
- **Trace Spectrum** - Allows you to place the selected marker on the **Spectrum, Spectrum Avg, or I/Q Waveform** trace. The default is **Spectrum**.
- **Off** - Allows you to turn off the selected marker.
- **Shape Diamond** - Allows you to access the menu to define the selected marker shape to be a **Diamond, Line, Square, or Cross**. The default is a **Diamond**.
- **Marker All Off** - Allows you to turn off all of the markers.

The front panel **Search** key performs a peak search when pressed. A marker will automatically be activated at the highest peak.

NOTE

In the Waveform measurement, the Mean Pwr (Entire Trace) value plus the Pk-to-Mean value will sum to equal the current Max Pt. value as shown in the data window below the RF Envelope display. If you do a marker peak search (**Search**) with averaging turned off, the marker will find the same maximum point. However, if you turn averaging on, the Pk-to-Mean value will use the highest peak found for any acquisition during averaging, while the marker peak will look for the peak of the display, which is the result of n-averages. This will usually result in differing values for the maximum point.

Band Power

A band power measurement using the markers calculates the average power between two adjustable markers. To make a band power measurement:

Press the **Marker** key.

Press **Function, Band Power**.

Two marker lines are activated at the extreme left side of the horizontal scale. Press **Normal** and move marker 1 to the desired place by rotating the **RPG** knob.

Press **Delta** to bring marker 2 to the same place as marker 1.

Move marker 1 to the other desired position by rotating the **RPG** knob. Band power measures the average power between the two markers. When the band power markers are active, the results are shown in the results window as Mean Pwr (Between Mks). When the band power function is off the results window reads Mean Pwr (Entire Trace).

Troubleshooting Hints

Changes made by the user to advanced waveform settings can inadvertently result in measurements that are invalid and cause error messages to appear. Care needs to be taken when using advanced features.

Making the Adjacent Channel Power Ratio (ACPR) Measurement

Purpose

Adjacent Channel Power Ratio (ACPR) is the power contained in a specified frequency channel bandwidth relative to the total carrier power. It may also be expressed as a ratio of power spectral densities between the carrier and the specified offset frequency. The absolute power at the specified offset is also provided in dBm, or dBm/Hz.

As a composite measurement of out-of-channel emissions, ACPR combines both in-band and out-of-band specifications to provide useful figures-of-merit for spectral regrowth and emissions produced by components and circuit blocks without the rigor of performing a full spectrum emissions mask measurement.

To maintain a quality call by avoiding channel interference, it is important to measure and reduce any adjacent channel leakage power transmitted from a mobile phone. The characteristics of adjacent channel leakage power are mainly determined by the transmitter design, particularly the low-pass filter.

Measurement Method

This measurement analyzes the total power levels within the defined carrier bandwidth and at given frequency offsets on both sides of the carrier frequency.

It uses an integration bandwidth (IBW) method that performs a time domain data acquisition and applies FFT to get a frequency domain trace. In this process, the channel integration bandwidth is analyzed using the automatically defined resolution bandwidth (RBW), which is much narrower than the channel bandwidth. The measurement computes an average power of the channel over a specified number of data acquisitions, automatically compensating for resolution bandwidth and noise bandwidth.

This measurement requires the user to specify measurement bandwidths of the carrier channel and each of the offset frequency pairs up to 5. Each pair may be defined with unique measurement bandwidths. If **Total Pwr Ref** is selected as the measurement type, the results are displayed as relative power in dBc and as absolute power in dBm. If **PSD** (Power Spectral Density reference) is selected, the results are displayed as relative power in dB, and as absolute power in dBm/Hz.

Recommended Offset Frequencies and Reference Bandwidths

While the user sets the specific offsets and reference bandwidths, there are some common setups. They are stated in the following table.

Table 3 ACPR Offsets

Band	Unit Under Test (UUT)	Offset Frequency	Reference (Integration) Bandwidth	Results Referenced to:
IS-95-A	Mobile	±900 kHz	30 kHz	Total power in 1.23 MHz
		1.98 MHz	30 kHz	
	Base	750 kHz	30 kHz	PSD Ref
		1.98 MHz	30 kHz	
J-STD-008	Mobile/Base	885 kHz	30 kHz	Total power in 1.23 MHz
		1.25625 MHz	12.5 kHz	
		2.75 MHz	1 MHz	

Making the Measurement

NOTE The factory default settings provide a good starting point. For special requirements, you may want to change some of the settings. Press **Meas Setup**, **More**, **Restore Meas Defaults** at any time to return all parameters for the current measurement to their default settings.

Select the desired center frequency.

Press **Measure**, **ACPR** to immediately make **Adjacent Channel Power Ratio (ACPR)** the active measurement.

To change any of the measurement parameters from the factory default values, refer to the “Changing the Measurement Setup” section below.

Results

The following figure shows an example result of ACPR (Total Pwr Ref) measurements in the bar graph window. The absolute and relative power levels on both sides of the carrier frequency are displayed in the graphic window and text window.

Figure 1 Adjacent Channel Power Ratio Measurement - Bar Graph View

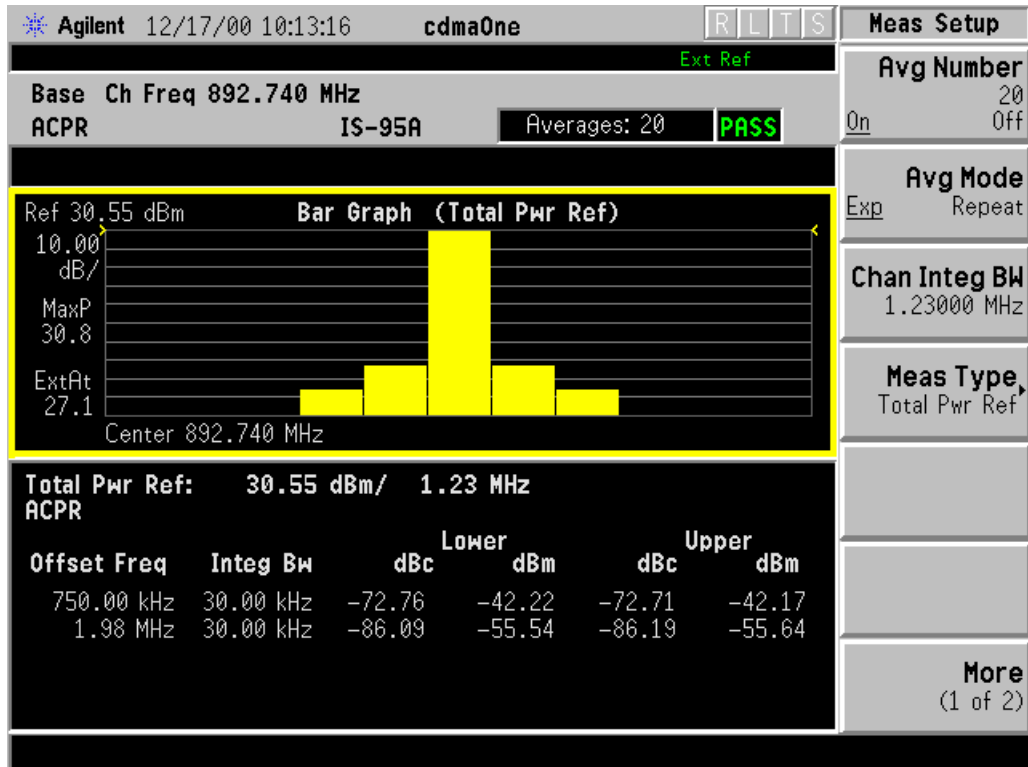
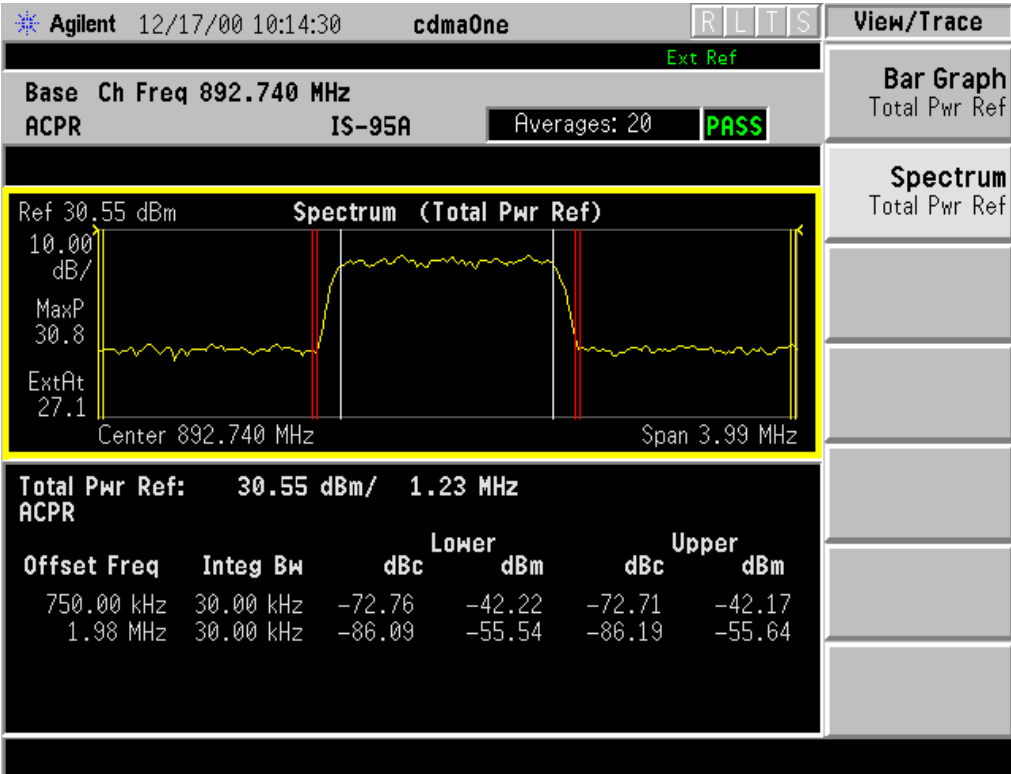

Figure 3-14 Adjacent Channel Power Ratio Measurement - Spectrum View



Changing the Measurement Setup

Table 3-6 Adjacent Channel Power Ratio Measurement Defaults

Measurement Parameter	Factory Default Condition
Spectrum Trace	On
Average Number	20 On
Average Mode	Repeat
Reference Channel	
Channel Integ BW	1.23000 MHz
Avg Type	Pwr Avg (RMS)
Offset Limits	
Offset	A
Offset Freq	750.000 kHz On (offset A)
Offset Side	Both
Ref BW	30.000 kHz
Avg Type	Pwr Avg (RMS)
Limit Setup	
Abs Limit	0.00 dBm
Fail	Relative
Rel Lim (Car)	-45.00 dBc (offset A)
Rel Lim (PSD)	-28.87 dB (offset A)
Measurement Type	Total Pwr Ref
Trigger Source	Free Run (Immediate)
Advanced	
Ref Chan Advanced	
Sweep Time	546.1 μ s Auto
Data Points	2048 Auto
Num FFT Seg	1 Auto
Dynamic Range	Normal
Offset Advanced	
Sweep Time	11.20 ms Auto
Data Points	1024 Auto
Num FFT Seg	1 Auto
Relative Att	0.00 dB, Auto

Make sure the **ACPR** measurement is selected under the **Measure** menu. The **Meas Setup** key accesses the menu which allows you to modify the average number and average mode for this measurement. In addition, the following parameters for adjacent channel power ratio measurements can be modified.

- **Chan Integ BW** - Allows you to specify the channel integration bandwidth in which the carrier power is measured. The range is 300 Hz to 20.0000 MHz with the best resolution of 1 Hz.
- **Meas Type** - Allows you to access the menu to select one of the measurement reference types.
 - Total Pwr Ref** - Sets the reference to the total carrier power.
 - PSD Ref** - Sets the reference to the mean power spectral density of the carrier.
- **Dyn Range**- allows you to optimize the dynamic range of the measurement in the following ways.
 - Normal** - lets the measurement automatically choose settings that trade off dynamic range for faster measurement speed. This is a good choice for making CDMA measurements on a signal with only one carrier turned on at a time.
 - High** - chooses settings that provide better dynamic range (better signal to noise ratio) at the expense of longer measurement times. This is a better choice for CDMA signals with multiple carriers turned on at the same time.
 - Modified**- is not a customer settable option. This choice is automatically selected depending on your selection of other related settings in the advanced measurement setup, like the number of FFT segments.
- **Ref Channel** - Allows you to access the following parameters for the reference channel settings:
 - Chan Integ BW** - Allows you to specify the channel integration bandwidth in which the carrier power is measured. The range is 1.000 kHz to 20.0000 MHz with the best resolution of 1 Hz.
 - Avg Type** - Choose the averaging type between **Pwr Avg (RMS)** and **Maximum**.
 - Ref Chan Adv** - Allows you to access the menu to change the following advanced parameters for the reference channel:
 - Sweep Time**
 - Data Points** - Allows you to select the number of data points. The automatic mode chooses the optimum number of points for the fastest measurement time with acceptable repeatability.

The minimum number of points that could be used is determined by the sweep time and the sampling rate. You can increase the length of the measured time record (capture more of the burst) by increasing the number of points, but the measurement will take longer.

Res BW - informational only

Num FFT Seg - Allows you to select the number of FFT segments used in making the measurement of the reference channel (carrier). In automatic mode the measurement optimizes the number of FFT segments required for the shortest measurement time. The minimum number of segments required to make a measurement is set by your desired measurement bandwidth. Selecting more than the minimum number of segments will give you more dynamic range for making the measurement, but the measurement will take longer to execute.

- **Offset/Limits** - Allows you to access the menu to change the following parameters for offset frequency settings and pass/fail tests:

Offset - Allows you to select one of five offsets (**A** through **E**). Only one selection at a time (**A**, **B**, **C**, **D**, or **E**) is shown on this key label. The remaining softkeys on the **Offset/Limits** menu then apply to the selected offset.

Offset Freq - Allows you to enter an offset frequency value and toggle the offset frequency function between **On** and **Off**. The range is 0.0 Hz to 45.000 MHz. While this key is activated, enter an offset value from the numeric keypad by terminating with one of the frequency unit keys shown. Offsets **A** and **B** are defaulted as follows, while others are defaulted to 0.0 Hz:

Offset A 750.000 kHz

Offset B 1.98000 MHz

One offset frequency value corresponding to the **Offset** key selection is shown on this key label.

Offset Side - Choose **Neg** (negative) or **Pos** (positive) to have single-sided offsets relative to the carrier, or **Both** (the default) to have offset frequency pairs.

Ref BW - Allows you to enter a reference bandwidth ranging from 300 Hz to 20.0000 MHz with the best resolution of 1 Hz. When this parameter is changed, the integration bandwidth **Integ BW** in the summary data window changes to that value.

Abs Limit - Allows you to enter an absolute limit value ranging from -200.00 to +50.00 dBm with 0.01 dB resolution.

Fail - Allows you to access the following menu to select one of the logic keys for fail conditions between the measurement results and the test limits:

AND - Fail is shown if one of the relative ACP measurement results is larger than **Rel Lim (Car)** or **Rel Lim (PSD)** AND one of the absolute ACP measurement results is larger than **Abs Limit**.

OR - Fail is shown if one of the relative ACP measurement results is larger than **Rel Lim (Car)** or **Rel Lim (PSD)** OR one of the absolute ACP measurement results is larger than **Abs Limit**.

Absolute - Fail is shown if one of the absolute ACP measurement results is larger than the absolute limit.

Relative - Fail is shown if one of the relative ACP measurement results is larger than **Rel Lim (Car)** or **Rel (PSD)**.

Rel Lim (Car)- Allows you to enter a relative limit value of the carrier level ranging from -150.00 to $+50.00$ dBc with 0.01 dB resolution. The default is -45.00 dBc for Offset A and -60.00 dBc for offset B.

Rel Lim (PSD)- Allows you to enter a relative limit value of the power spectral density level ranging from -150.00 to $+50.00$ dB with 0.01 dB resolution. The default is -28.87 dB for Offset A and -43.87 dB for offset B.

Avg Type - Choose the type of averaging between **Pwr Avg (RMS)** or **Maximum**.

Limit Setup -

Abs Limit - Allows you to enter an absolute limit value ranging from -200.00 to $+50.00$ dBm with 0.01 dB resolution.

Fail - Allows you to access the following menu to select one of the logic keys for fail conditions between the measurement results and the test limits:

AND - Fail is shown if one of the relative ACP measurement results is larger than **Rel Lim (Car)** or **Rel Lim (PSD)** AND one of the absolute ACP measurement results is larger than **Abs Limit**.

OR - Fail is shown if one of the relative ACP measurement results is larger than **Rel Lim (Car)** or **Rel Lim (PSD)** OR one of the absolute ACP measurement results is larger than **Abs Limit**.

Absolute - Fail is shown if one of the absolute ACP measurement results is larger than **Abs Limit**.

Relative - Fail is shown if one of the relative ACP measurement results is larger than **Rel Lim (Car)** or **Rel (PSD)**.

Rel Lim (Car)- Allows you to enter a relative limit value of the carrier level ranging from -150.00 to $+50.00$ dBc with 0.01 dB resolution. The default is -45.00 dBc for Offset A and -60.00 dBc for offset B.

Rel Lim (PSD)- Allows you to enter a relative limit value of the power spectral density level ranging from -150.00 to $+50.00$ dB with 0.01 dB resolution. The default is -28.87 dB for Offset A and -43.87 dB for offset B.

Offset Adv - Allows you to access the menu to change the following advanced offset parameters:

Sweep Time

Data Points - Allows you to select the number of data points. The automatic mode chooses the optimum number of points for the fastest measurement time with acceptable repeatability. The minimum number of points that could be used is determined by the sweep time and the sampling rate. You can increase the length of the measured time record (capture more of the burst) by increasing the number of points, but the measurement will take longer.

Res BW - informational only

Num FFT Seg - The automatic mode selects the optimum number of FFT segments to measure the offset, while making the fastest possible measurement.

Relative Att - Allows you to set a relative amount of attenuation for the measurements made at your offsets. The amount of attenuation is always specified relative to the attenuation that is required to measure the carrier channel. Since the offset channel power is lower than the carrier channel power, less attenuation is required to measure the offset channel and you get wider dynamic range for the measurement.

- **Meas Type** - Allows you to access the menu to select one of the measurement reference types.

Total Pwr Ref - Sets the reference to the total carrier power.

PSD Ref - Sets the reference to the mean power spectral density of the carrier.

- **Spectrum Trace**

Turns off the spectrum trace data calculations. This is only applicable when using the Spectrum View. It speeds up the display of the other measured data values by not calculating the spectrum trace.

Changing the View

The **View/Trace** key accesses the menu to select the desired view of the measurement.

- **Bar Graph** - In the factory default condition, 5 of the total integration power levels, centered at the carrier frequency and ± 750.0 kHz and ± 1.98 MHz offset frequencies, for example, are shown in the graph window. The corresponding measured data is shown in the text window. Depending on the **Meas Type** setting, one of the two following displays is obtained:

Bar Graph (Total Pwr Ref) - A histogram of powers referenced to the total power

Bar Graph (PSD Ref) - A histogram of powers referenced to the mean power spectral density of the carrier in dBm/Hz

- **Spectrum** - In the factory default condition, the frequency spectrum with the FFT sweep type is displayed with the bandwidth marker lines in the graph window. The corresponding measured data in the text window is the total integration power levels, in dBc and dBm, within the defined bandwidth as shown in the figure below. Depending on the **Meas Type** setting, one of the two following displays is obtained:

Spectrum (Total Pwr Ref) - A spectrum display referenced to the total power

Spectrum (PSD Ref) - A spectrum display referenced to the mean power spectral density of the carrier in dBm/Hz

You can improve the update speed of the displayed data values by turning off the spectrum trace in **Meas Setup**.

Troubleshooting Hints

This adjacent channel power ratio measurement can reveal degraded or defective parts in the transmitter section of the UUT. The following examples are those areas to be checked further.

- Some faults in the DC power supply control of the transmitter power amplifier, RF power controller of the pre-power amplifier stage, or I/Q control of the baseband stage
- Some degradation in the gain and output power level of the amplifier due to the degraded gain control and/or increased distortion
- Some degradation of the amplifier linearity and other performance characteristics

Power amplifiers are one of the final stage elements of a base or mobile transmitter and are a critical part of meeting the important power and spectral efficiency specifications. Since ACPR measures the spectral response of the amplifier to a complex wideband signal, it is a key measurement linking amplifier linearity and other performance characteristics to the stringent system specifications.